

Solenoid valve(5/2 way, 5/3 way)

4V100 Series

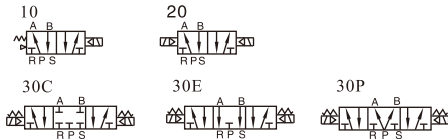

Symbol



Product feature

1. Pilot-oriented mode: Internal pilot or external pilot.
2. Structure in sliding column mode: good tightness and sensitive reaction .
3. Three position solenoid valves have three kinds of central function for your choice.
4. Double control solenoid valves have memory function.
5. Internal hole adopts special processing technology which has little attrition friction, low start pressure and long service life.
6. No need to add oil for lubrication.
7. It is available to form integrated valve group with the base to save installation space.
8. Affiliated manual devices are equipped to facilitate installation and debugging.
9. Several standard voltage grades are optional.

Specification

Model	4V110-M5 4V120-M5	4V130C-M5 4V130E-M5 4V130P-M5	4V110-06 4V120-06	4V130C-06 4V130E-06 4V130P-06
Fluid	Air(to be filtered by 40 μm filter element)			
Acting	Internal pilot or external pilot			
Port size [Note1]	In=Out=M5		In=Out=1/8"	
Orifice size	5.5mm ² (Cv=0.31)	5.0mm ² (Cv=0.28)	12.0mm ² (Cv=0.67)	9.0mm ² (Cv=0.50)
Valve type	5 port 2 position	5 port 3 position	5 port 2 position	5 port 3 position
Operating pressure	0.15~0.8MPa(21~114psi)			
Proof pressure	1.2MPa(175psi)			
Temperature	-20~70°C			
Material of body	Aluminum alloy			
Lubrication [Note2]	Not required			
Max.frequency [Note3]	5 cycle/sec	3cycle/sec	5 cycle/sec	3 cycle/sec
Weight (g)	4V110-M5:120 4V120-M5:175	200	4V110-06:120 4V120-06:175	200

[Note1] PT thread, G thread and NPT thread are available.

[Note2] Once lubricated air is used, continue with same medium to optimise valve life span. Lubricants like ISO VG32 or equivalent are recommended.

[Note3] The maximum actuation frequency is in the no-load state.

Coil specification

Item	specification				
Standard voltage	AC220V	AC110V	AC24V	DC24V	DC12V
Scope of voltage	AC: ± 15% DC: ± 10%				
Power consumption	3.5VA	3.5VA	4.0VA	2.5W	2.5W
Protection	IP65(DIN40050)				
Temperature classification	B Class				
Electrical entry	Terminal, Grommet				
Activating time	0.05 sec and below				

Ordering code

4V 1 10 06 A □ □

① ② ③ ④ ⑤ ⑥ ⑦

① Model	② Code	③ Valve type	④ Port size	⑤ Voltage	⑥ Electrical entry	⑦ Thread type
4V: Solenoid valve (5/2, 5/3 way)	1: 100 Series	10: Single solenoid 5/2 way 20: Double solenoid 5/2 way 30C: Double solenoid 5/3 way closed center 30E: Double solenoid 5/3 way exhaust center 30P: Double solenoid 5/3 way pressure center	M5: M5 06: 1/8"	A: AC220V B: DC24V C: AC110V E: AC24V F: DC12V	Blank: Terminal I: Grommet	No this code Blank: PT G: G T: NPT

Please refer to 27 for manifold specification and the order way.

Flow chart

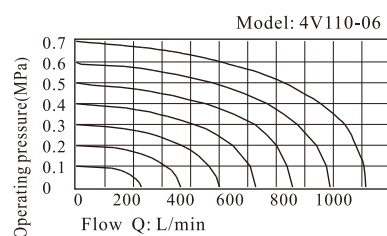
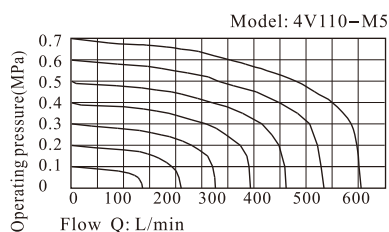

Solenoid valve(5/2 way, 5/3 way)

4V100 Series

Inner structure

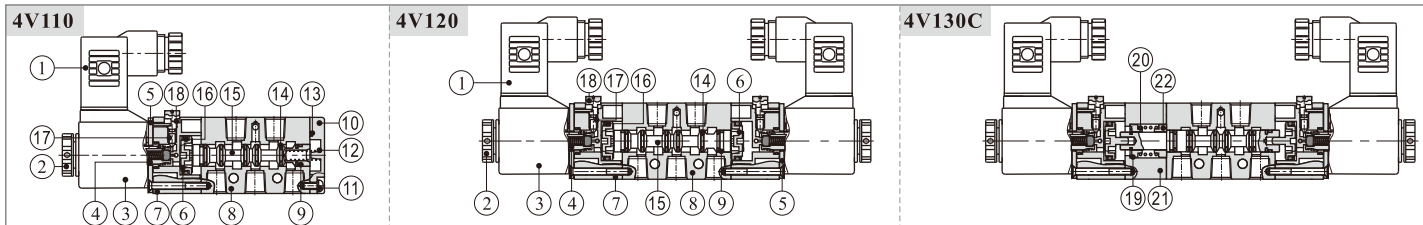

No.	Item	No.	Item	No.	Item	No.	Item	No.	Item	No.	Item	No.	Item	No.	Item	No.	Item	No.	Item		
1	Connector	3	Coil	5	Fixed plate	7	Pilot kit	9	Wear ring	11	Fixed screw	13	Bottom cover gasket	15	Spool	17	Override spring	19	Spring holder	21	Side cover
2	Coil net	4	Armature	6	Piston	8	Body	10	Bottom cover	12	Spool spring	14	Spool O-ring	16	Piston O-ring	18	Manual override	20	Return spring	22	Spring holder

Dimensions

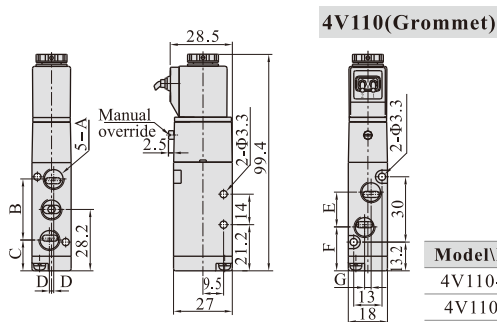
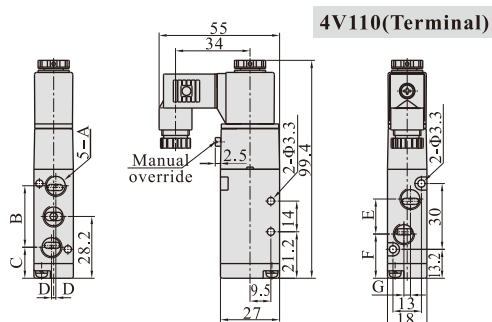

Model/Item	A	B	C	D	E	F	B
4V110-M5	M5x0.8	27	14.7	0	14	21.2	0
4V110-06	1/8"	28	14.2	1	16	20.2	3

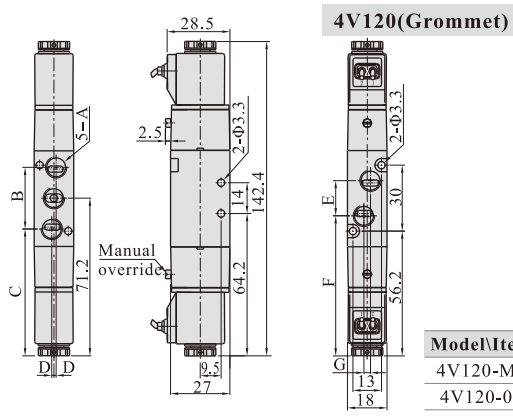
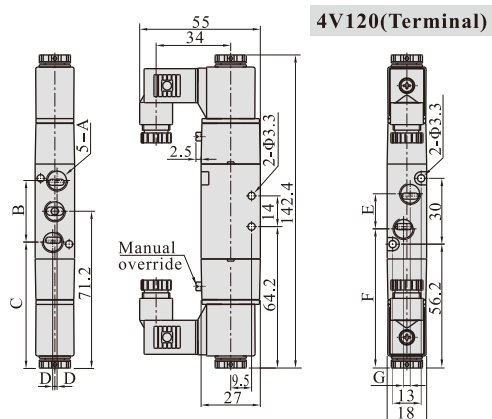

Model/Item	A	B	C	D	E	F	G
4V120-M5	M5x0.8	27	57.7	0	14	64.3	0
4V120-06	1/8"	28	57.2	1	16	63.2	3

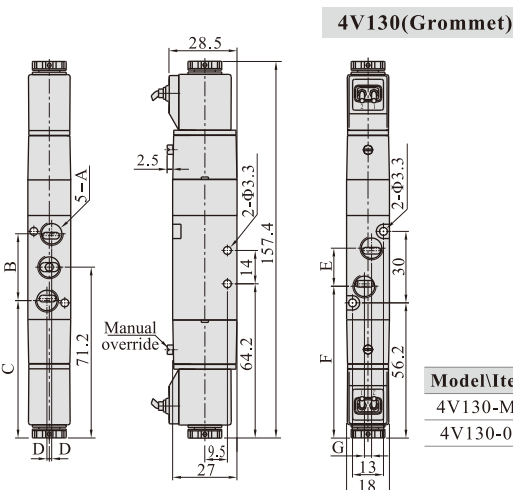
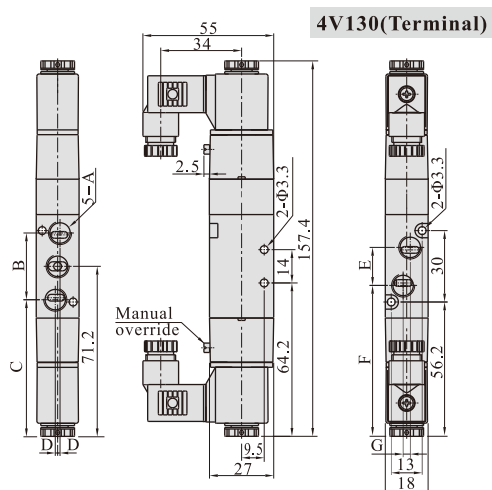

Model/Item	A	B	C	D	E	F	G
4V130-M5	M5x0.8	27	57.7	0	14	64.3	0
4V130-06	1/8"	28	57.2	1	16	63.2	3

Solenoid valve(5/2 way, 5/3 way)

4V200 Series



Symbol

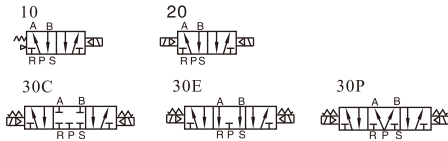

Product feature

1. Pilot-oriented mode: Internal pilot or external pilot.
2. Structure in sliding column mode: good tightness and sensitive reaction.
3. Three position solenoid valves have three kinds of central function for your choice.
4. Double control solenoid valves have memory function.
5. Internal hole adopts special processing technology which has little attrition friction, low start pressure and long service life.
6. No need to add oil for lubrication.
7. It is available to form integrated valve group with the base to save installation space.
8. Affiliated manual devices are equipped to facilitate installation and debugging.
9. Several standard voltage grades are optional.

Specification

Model	4V210-06 4V220-06	4V230C-06 4V230E-06 4V230P-06	4V210-08 4V220-08	4V230C-08 4V230E-08 4V230P-08
Fluid	Air(to be filtered by 40 μm filter element)			
Acting	Internal pilot or external pilot			
Port size [Note1]	In=Out=Exhaust=1/8"		In=Out=1/4" Exhaust=1/8"	
Orifice size	14.0mm ² (Cv=0.78)	12.0mm ² (Cv=0.67)	16.0mm ² (Cv=0.89)	12.0mm ² (Cv=0.67)
Valve type	5 port 2 position	5 port 3 position	5 port 2 position	5 port 3 position
Operating pressure	0.15~0.8MPa(21~114psi)			
Operating pressure	1.2MPa(175psi)			
Temperature	-20~70°C			
Material of body	Aluminum alloy			
Lubrication [Note2]	Not required			
Max. frequency [Note3]	5 cycle/sec	3 cycle/sec	5 cycle/sec	3 cycle/sec
Weight (g)	4V210-06:220 4V220-06:320	360	4V210-08:220 4V220-08:320	360

[Note1] PT thread, G thread and NPT thread are available.

[Note2] Once lubricated air is used, continue with same medium to optimise valve life span. Lubricants like ISO VG32 or equivalent are recommended.

[Note3] The maximum actuation frequency is in the no-load state.

Coil specification

Item	specification				
Standard voltage	AC220V	AC110V	AC24V	DC24V	DC12V
Scope of voltage	AC: ±15% DC: ±10%				
Power consumption	4.5VA	4.5VA	5.0VA	3.0W	3.0W
Protection	IP65(DIN40050)				
Temperature classification	B Class				
Electrical entry	Terminal, Grommet				
Activating time	0.05 sec and below				

Ordering code

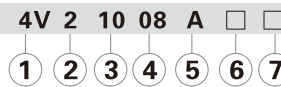

① Model	② Code	③ Valve type	④ Port size	⑤ Voltage	⑥ Electrical entry	⑦ Thread type
4V: Solenoid valve (5/2, 5/3 way)	2: 200 Series	10: Single solenoid 5/2 way 20: Double solenoid 5/2 way 30C: Double solenoid 5/3 way closed center 30E: Double solenoid 5/3 way exhaust center 30P: Double solenoid 5/3 way pressure center	06: 1/8" 08: 1/4"	A: AC220V B: DC24V C: AC110V E: AC24V F: DC12V	Blank: Terminal I: Grommet	Blank: PT G: G T: NPT

Please refer to 27 for manifold specification and the order way.

Flow chart

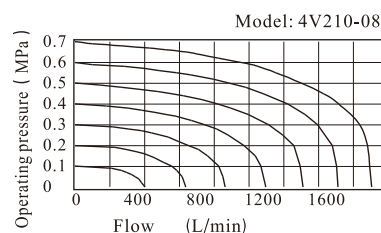
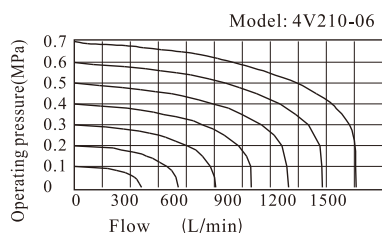

Solenoid valve(5/2 way, 5/3 way)

4V200 Series

Inner structure

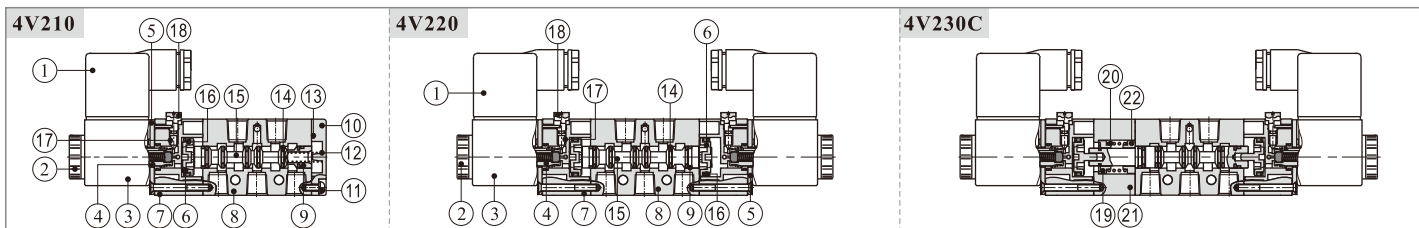

No.	Item	No.	Item	No.	Item	No.	Item	No.	Item	No.	Item	No.	Item	No.	Item	No.	Item	No.	Item	No.	Item
1	Connector	3	Coil	5	Fixed plate	7	Pilot kit	9	Wear ring	11	Fixed screw	13	Bottom cover gasket	15	Spool	17	Override spring	19	Spring holder	21	Side cover
2	Coil net	4	Armature	6	Piston	8	Body	10	Bottom cover	12	Spool spring	14	Spool O-ring	16	Piston O-ring	18	Manual override	20	Return spring	22	Spring holder

Dimensions

4V210(Terminal)

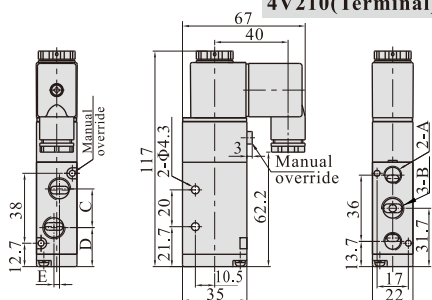

4V210(Grommet)

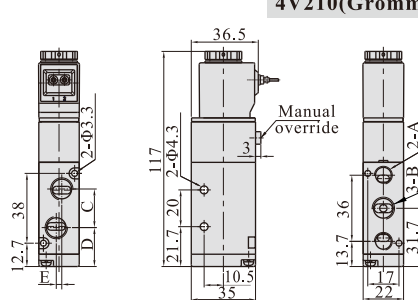

Model/Item	A	B	C	D	E
4V210-06	1/8"	1/8"	18	22.7	0
4V210-08	1/8"	1/4"	21	21.2	3

4V220(Terminal)

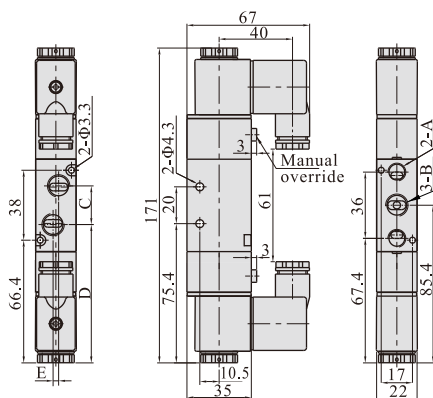

4V220(Grommet)

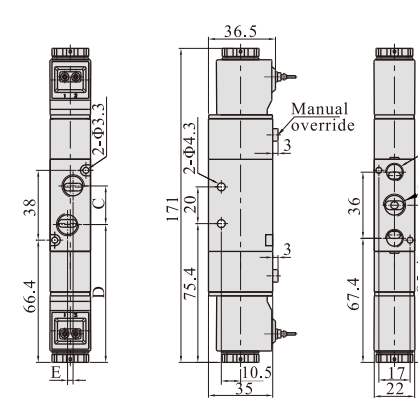

Model/Item	A	B	C	D	E
4V220-06	1/8"	1/8"	18	76.4	0
4V220-08	1/8"	1/4"	21	74.9	3

4V230(Terminal)

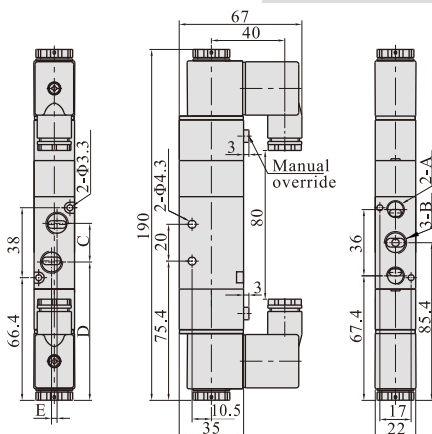

4V230(Grommet)

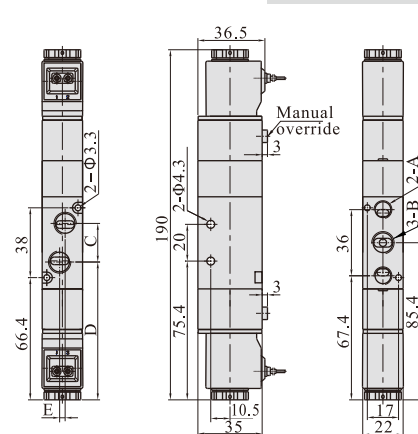

Model/Item	A	B	C	D	E
4V230-06	1/8"	1/8"	18	76.4	0
4V230-08	1/8"	1/4"	21	74.9	3

Solenoid valve(5/2 way, 5/3 way)

4V300 Series



Symbol

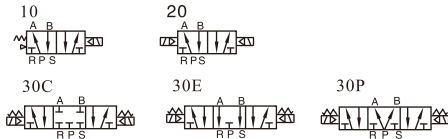

Product feature

1. Pilot-oriented mode: Internal pilot or external pilot.
2. Structure in sliding column mode: good tightness and sensitive reaction.
3. Three position solenoid valves have three kinds of central function for your choice.
4. Double control solenoid valves have memory function.
5. Internal hole adopts special processing technology which has little attrition friction, low start pressure and long service life.
6. No need to add oil for lubrication.
7. It is available to form integrated valve group with the base to save installation space.
8. Affiliated manual devices are equipped to facilitate installation and debugging.
9. Several standard voltage grades are optional.

Specification

Model	4V310-08 4V320-08	4V330C-08 4V330E-08 4V330P-08	4V310-10 4V320-10	4V330C-10 4V330E-10 4V330P-10
Fluid	Air(to be filtered by 40 μm filter element)			
Acting	Internal pilot or external pilot			
Port size [Note1]	In=Out=Exhaust=1/4"		In=Out=3/8"	Exhaust=1/4"
Orifice size	25.0mm ² (Cv=1.40)	18.0mm ² (Cv=1.00)	30.0mm ² (Cv=1.68)	18.0mm ² (Cv=1.00)
Valve type	5 port 2 position	5 port 3 position	5 port 2 position	5 port 3 position
Operating pressure	0.15~0.8MPa(21~114psi)			
Proof pressure	1.2MPa(175psi)			
Temperature	-20~70°C			
Material of body	Aluminum alloy			
Lubrication [Note2]	Not required			
Max. frequency [Note3]	4 cycle/sec	3 cycle/sec	4 cycle/sec	3 cycle/sec
Weight (g)	4V310-08:310 4V320-08:400	450	4V310-10:310 4V320-10:400	450

[Note1] PT thread, G thread and NPT thread are available.

[Note2] Once lubricated air is used, continue with same medium to optimise valve life span. Lubricants like ISO VG32 or equivalent are recommended.

[Note3] The maximum actuation frequency is in the no-load state.

Coil specification

Item	specification				
Standard voltage	AC220V	AC110V	AC24V	DC24V	DC12V
Scope of voltage	AC: ±15% DC: ±10%				
Power consumption	4.5VA	4.5VA	5.0VA	3.0W	3.0W
Protection	IP65(DIN40050)				
Temperature classification	B Class				
Electrical entry	Terminal, Grommet				
Activating time	0.05 sec and below				

Ordering code

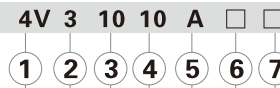

① Model	② Code	③ Valve type	④ Port size	⑤ Voltage	⑥ Electrical entry	⑦ Thread type
4V: Solenoid valve (5/2, 5/3 way)	3: 300 Series	10: Single solenoid 5/2 way 20: Double solenoid 5/2 way 30C: Double solenoid 5/3 way closed center 30E: Double solenoid 5/3 way exhaust center 30P: Double solenoid 5/3 way pressure center	08: 1/4" 10: 3/8"	A: AC220V B: DC24V C: AC110V E: AC24V F: DC12V	Blank: Terminal I: Grommet	Blank: PT G: G T: NPT

Please refer to 27 for manifold specification and the order way.

Flow chart

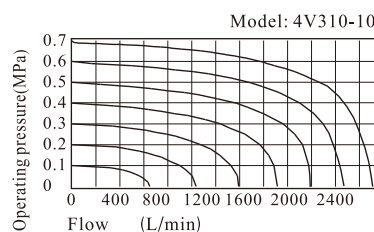
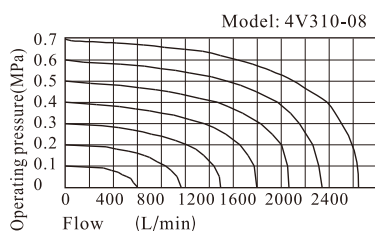

Solenoid valve(5/2 way, 5/3 way)

4V300 Series

Inner structure

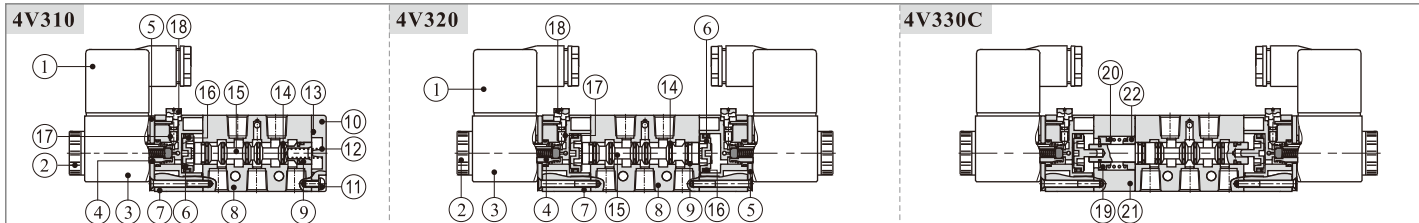

No.	Item	No.	Item	No.	Item	No.	Item	No.	Item	No.	Item	No.	Item	No.	Item	No.	Item				
1	Connector	3	Coil	5	Fixed plate	7	Pilot kit	9	Wear ring	11	Fixed screw	13	Bottom cover gasket	15	Spool	17	Override spring	19	Spring holder	21	Side cover
2	Coil net	4	Armature	6	Piston	8	Body	10	Bottom cover	12	Spool spring	14	Spool O-ring	16	Piston O-ring	18	Manual override	20	Return spring	22	Spring holder

Dimensions

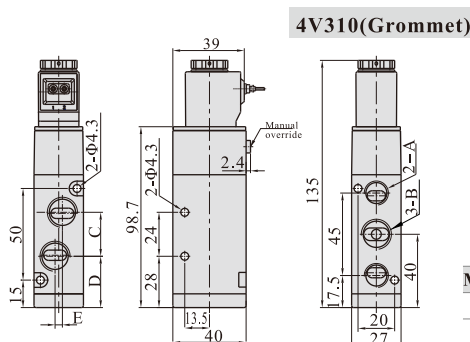
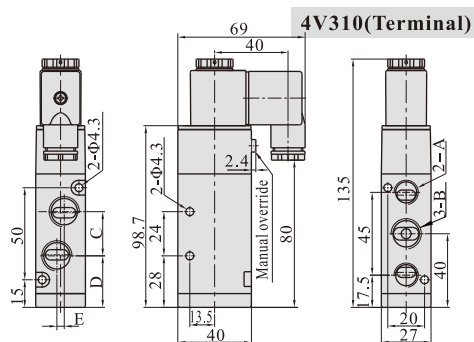

Model\Item	A	B	C	D	E
4V310-08	1/4"	1/4"	22	29	0
4V310-10	1/4"	3/8"	24	28	4

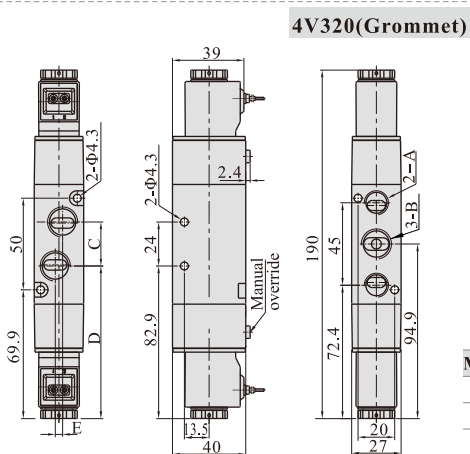
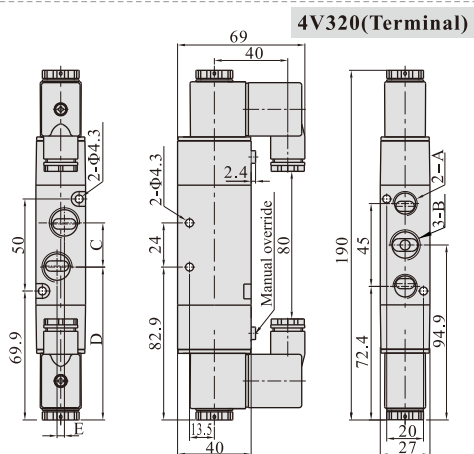

Model\Item	A	B	C	D	E
4V320-08	1/4"	1/4"	22	83.9	0
4V320-10	1/4"	3/8"	24	82.9	4

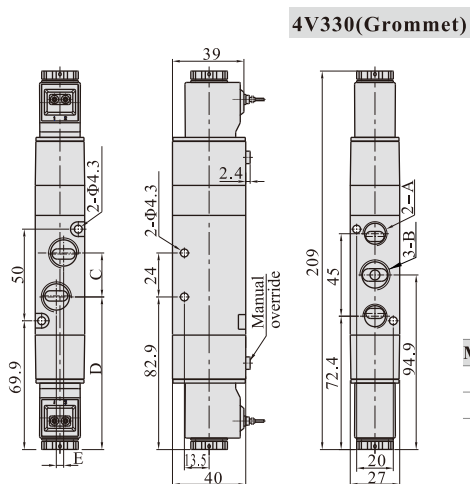
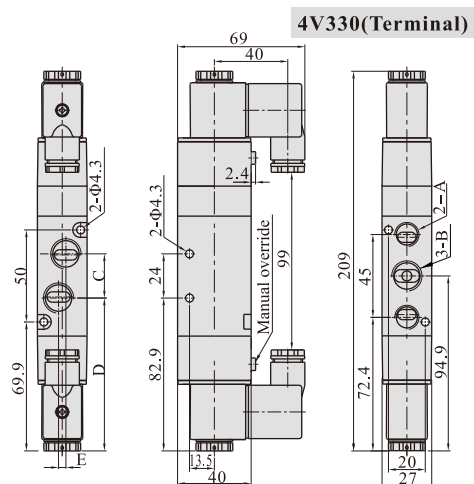

Model\Item	A	B	C	D	E
4V330-08	1/4"	1/4"	22	83.9	0
4V330-10	1/4"	3/8"	24	82.9	4

Solenoid valve(5/2 way, 5/3 way)

4V400 Series



Symbol

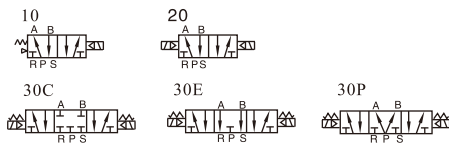

Specification

Model	4V410-15	4V420-15	4V430C-15	4V430E-15	4V430P-15
Fluid	Air(to be filtered by 40 μm filter element)				
Acting	Internal pilot or external pilot				
Port size [Note1]	In=Out=Exhaust=1/2"				
Orifice size	50.0mm ² (Cv=2.79)		30.0mm ² (Cv=1.68)		
Valve type	5 port 2 position		5 port 3 position		
Operating pressure	0.15~0.8MPa(21~114psi)				
Proof pressure	1.2MPa(175psi)				
Temperature	-20~70°C				
Material of body	Aluminum alloy				
Lubrication [Note2]	Not required				
Max. frequency [Note3]	3 cycle/sec				
Weight (g)	590	720		770	

[Note1] PT thread, G thread and NPT thread are available.

[Note2] Once lubricated air is used, continue with same medium to optimise valve life span. Lubricants like ISO VG32 or equivalent are recommended.

[Note3] The maximum actuation frequency is in the no-load state.

Product feature

1. Pilot-oriented mode: Internal pilot or external pilot.
2. Structure in sliding column mode: good tightness and sensitive reaction.
3. Three position solenoid valves have three kinds of central function for your choice.
4. Double control solenoid valves have memory function.
5. Internal hole adopts special processing technology which has little attrition friction, low start pressure and long service life.
6. No need to add oil for lubrication.
7. It is available to form integrated valve group with the base to save installation space.
8. Affiliated manual devices are equipped to facilitate installation and debugging.
9. Several standard voltage grades are optional.

Coil specification

Item	specification				
Standard voltage	AC220V	AC110V	AC24V	DC24V	DC12V
Scope of voltage	AC: ±15% DC: ±10%				
Power consumption	4.5VA	4.5VA	5.0VA	3.0W	3.0W
Protection	IP65(DIN40050)				
Temperature classification	B Class				
Electrical entry	Terminal, Grommet				
Activating time	0.05 sec and below				

Ordering code

4V 4 10 15 A □ □



① Model	② Code	③ Valve type	④ Port size	⑤ Voltage	⑥ Electrical entry	⑦ Thread type
4V: Solenoid valve (5/2, 5/3 way)	4: 400 Series	10: Single solenoid 5/2 way 20: Double solenoid 5/2 way 30C: Double solenoid 5/3 way closed center 30E: Double solenoid 5/3 way exhaust center 30P: Double solenoid 5/3 way pressure center	15: 1/2"	A: AC220V B: DC24V C: AC110V E: AC24V F: DC12V	Blank: Terminal I: Grommet	Blank: PT G: G T: NPT

Please refer to 27 for manifold specification and the order way.

Flow chart

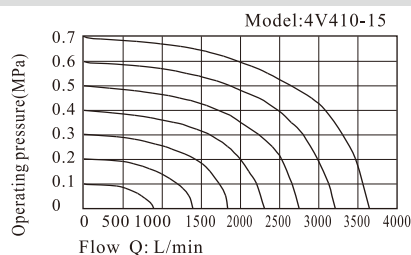

Solenoid valve(5/2 way, 5/3 way)

4V400 Series

Inner structure

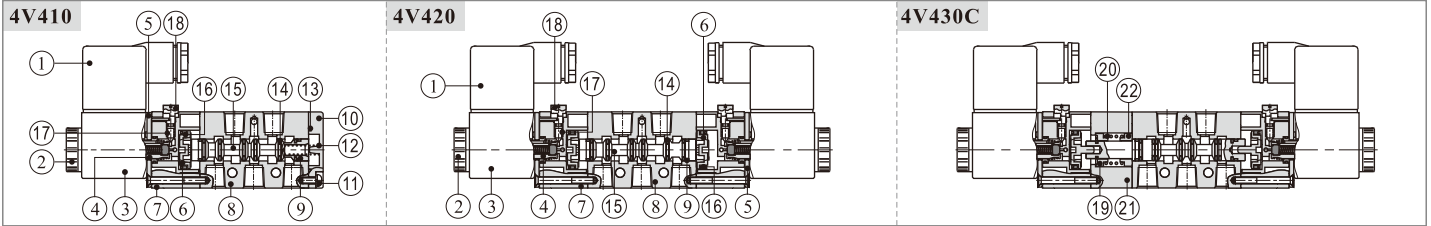

No.	Item	No.	Item	No.	Item	No.	Item	No.	Item	No.	Item	No.	Item	No.	Item	No.	Item	No.	Item	No.	Item
1	Connector	3	Coil	5	Fixed plate	7	Pilot kit	9	Wear ring	11	Fixed screw	13	Bottom cover gasket	15	Spool	17	Override spring	19	Spring holder	21	Side cover
2	Coil net	4	Armature	6	Piston	8	Body	10	Bottom cover	12	Spool spring	14	Spool O-ring	16	Piston O-ring	18	Manual override	20	Return spring	22	Spring holder

Dimensions

4V410(Terminal)

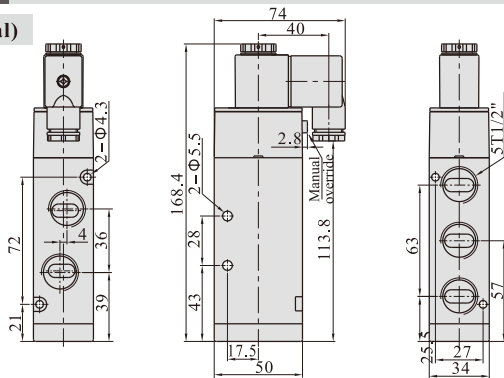

4V410(Grommet)

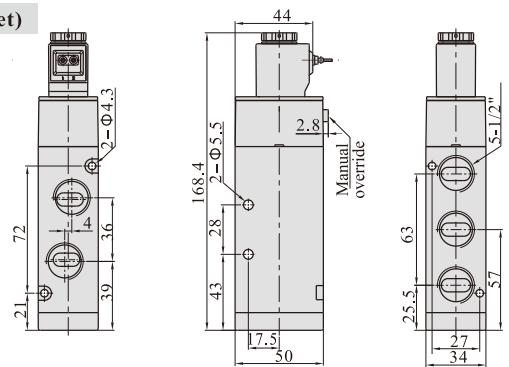

4V420(Terminal)

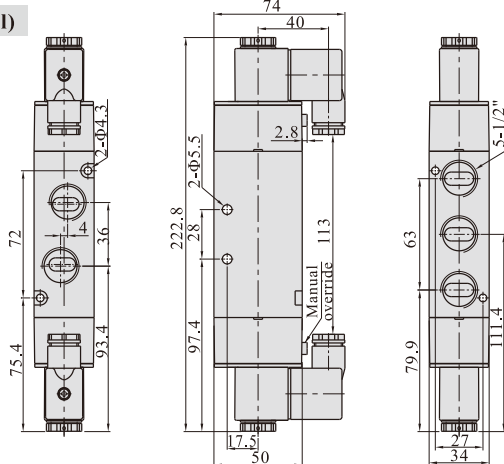

4V420(Grommet)

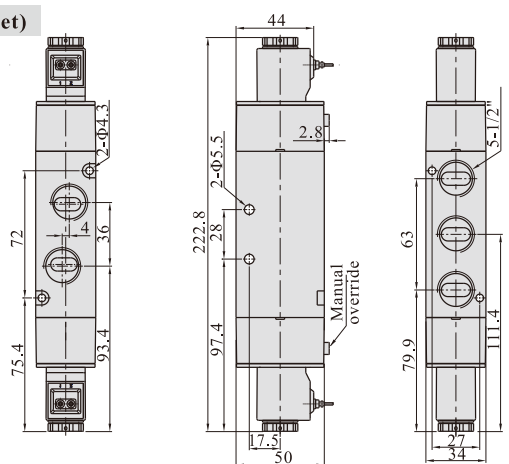

4V430(Terminal)

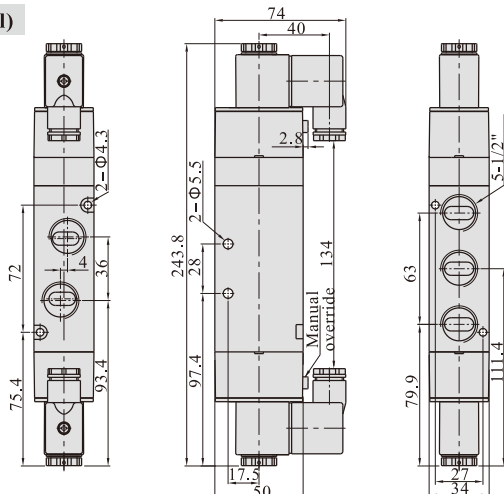

4V430(Grommet)

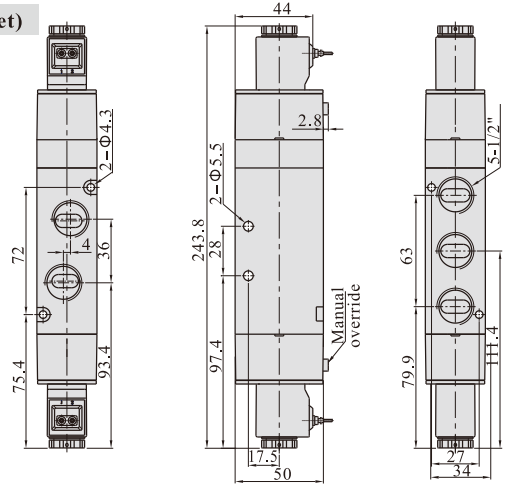

Manifold

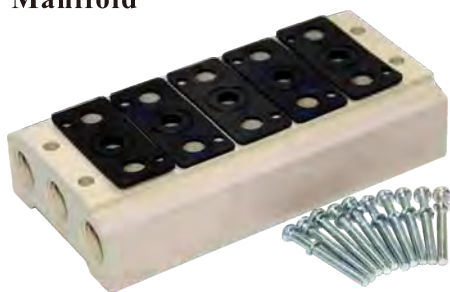

Specification

Item\Manifold Model	100M	200M	300M	400M
Fluid	Air(to be filtered by 40 μ m filter element)			
Temperature	-20~70°C			
Adaptable valve's series	4V100 Series	4V200 Series	4V300 Series	4V400 Series

Product feature

1. It is available to integrate the direction control valves of the same series to form valve group to save space and cost.
2. It is easy to examine when there are faults owing to the unified air intake and exhaust and unified wiring.
3. Flexible combination and strong expansion capability can make any combination or expansion of the numbers of direction control valves that are connected.

Ordering code

Ordering code for manifold

100M 5F □

① ② ③

① Model	② Number of stations [Note1]	③ Thread type
100M:100 Series manifold 200M:200 Series manifold 300M:300 Series manifold 400M:400 Series manifold	1F: 1 Station 2F: 2 Station 3F: 3 Station 16F: 16 Station	Blank: PT G: G T: NPT

Ordering code for blank plate

P-100M-R2

① ② ③

① Kits model	② Model	③ Code
P: Kits	100M: 100 Series manifold 200M: 200 Series manifold 300M: 300 Series manifold 400M: 400 Series manifold	R2: Blank plate for manifold

[Note1] 100M, 200M series have a maximum of 16 stations ; 300M series have a maximum of 12 stations; 400M series have a maximum of 8 stations.

[Note] 1. Ordering code contains the two parts of the manifold's and the blank plate's. 2. Manifold kits contains manifold, seal and screw.

3. Blank plate kits contains blank plate and screw.

Dimensions

With 4V solenoid valve

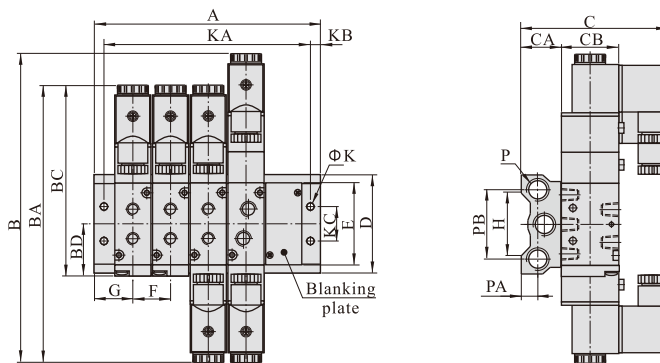

Model\Item	B	BA	BC	BD	C	CA	CB	D	E	F	G	H	K	KB	KC	P	PA	PB
100M□F	154.5	142.5	99.5	28	78	23	27	57.5	43	19	19	36	4.5	5	20	1/4"	10	40
200M□F	189	171	117	31.7	92	25	35	60	52	23	22	38	4.5	5	21	1/4"	10	42
300M□F	208	190	135	40	98	29	40	75	64	28	26	54	4.5	5	26	3/8"	13.5	53
400M□F	243	223	168.5	57	108	34	50	100	94	35	30.5	75	5.5	6	32	1/2"	15	68

Model\Item	A															
	1F	2F	3F	4F	5F	6F	7F	8F	9F	10F	11F	12F	13F	14F	15F	16F
100M□F	38	57	76	95	114	133	152	171	190	209	228	247	266	285	304	323
200M□F	44	67	90	113	136	159	182	205	228	251	274	297	320	343	366	389
300M□F	52	80	108	136	164	192	220	248	276	304	332	360	-	-	-	-
400M□F	61	96	131	166	201	236	271	306	-	-	-	-	-	-	-	-

Model\Item	KA															
	1F	2F	3F	4F	5F	6F	7F	8F	9F	10F	11F	12F	13F	14F	15F	16F
100M□F	28	47	66	85	104	123	142	161	180	199	218	237	256	275	294	313
200M□F	34	57	80	103	126	149	172	195	218	241	264	287	310	333	356	379
300M□F	42	70	98	126	154	182	210	238	266	294	322	350	-	-	-	-
400M□F	49	84	119	154	189	224	259	294	-	-	-	-	-	-	-	-