

3V100 Series



Specification

Model	3V110-M5	3V120-M5	3V110-06	3V120-06
Fluid	Air(to be filtered by 40 μm filter element)			
Acting	Internal pilot or external pilot			
Port size [Note1]	M5		1/8"	
Orifice size	5.5mm ² (Cv=0.31)		12.0mm ² (Cv=0.67)	
Valve type	3 port 2 position			
Lubrication [Note2]	Not required			
Operating pressure	0.15~0.8MPa(21~114psi)			
Proof pressure	1.2MPa(175psi)			
Temperature	-20~70°C			
Material of body	Aluminum alloy			

[Note 1] PT thread, G thread and NPT thread are available.

[Note 2] Once lubricated air is used, continue with same medium to optimise valve life span. Lubricants like ISO VG32 or equivalent are recommended.

Symbol

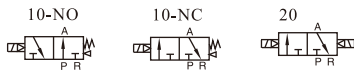

Product feature

1. Pilot-oriented mode: Internal pilot or external pilot.
2. Structure in sliding column mode: good tightness and sensitive reaction.
3. Double control solenoid valves have memory function.
4. Internal hole adopts special processing technology which has little attrition friction, low start pressure and long service life.
5. No need to add oil for lubrication.
6. Affiliated manual devices are equipped to facilitate installation and debugging.
7. Several standard voltage grades are optional.
8. Integrate with the manifold to save installation space.

Coil specification

Item	specification				
Standard voltage	AC220V	AC110V	AC24V	DC24V	DC12V
Scope of voltage	AC: ±15% DC: ±10%				
Power consumption	3.5VA	3.5VA	4.0VA	2.5W	2.5W
Protection	IP65(DIN40050)				
Temperature classification	B Class				
Electrical entry	Terminal, Grommet				
Activating time	0.05 sec and below				
Max. frequency [Note 1]	5 cycle/sec				

[Note 1] The maximum actuation frequency is in the no-load state.

Ordering code

3V 1 10 06 NO A □ □



① Model	② Code	③ Valve type	④ Port size	⑤ Acting type	⑥ Standard voltage	⑦ Electrical entry	⑧ Thread type
3V:Solenoid valve (3/2 way)	1: 100 Series	10: Single solenoid	M5: M5 06: 1/8"	NC: Normally closed NO: Normally opened	A: AC220V B: DC24V C: AC110V E: AC24V F: DC12V	Blank: Terminal I: Grommet	M5
		20: Double solenoid		No this code			No this code

Please refer to 26 for manifold specification and the order way.

Flow chart

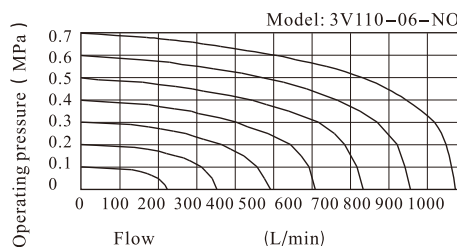

Solenoid valve(3/2 way)

3V100 Series

Inner structure

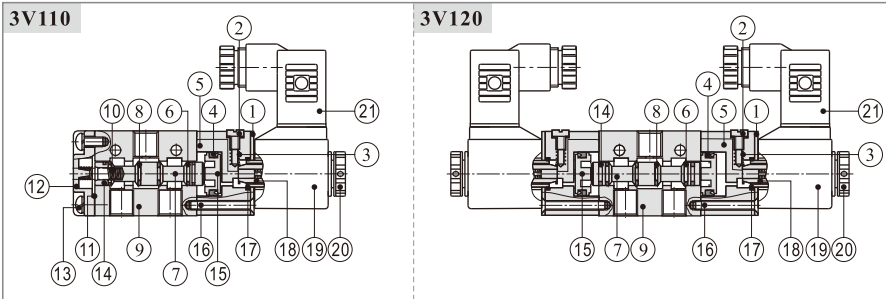

No.	Item	No.	Item	No.	Item
1	Fixed plate	8	O-ring	15	Piston
2	Manual override	9	Body	16	Pilot screw
3	Override spring	10	Spool spring	17	O-ring
4	Piston O-ring	11	Bottom cover gasket	18	Armature
5	Pilot body	12	Bottom cover	19	Coil
6	Spool packing	13	Screw	20	Coil net
7	Spool	14	Wear ring	21	Connector

Dimensions

3V110(Terminal)

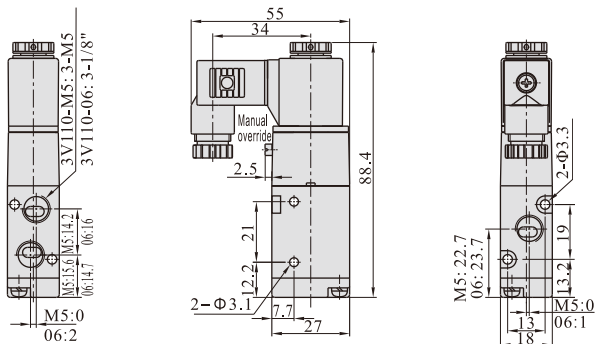

3V110(Grommet)

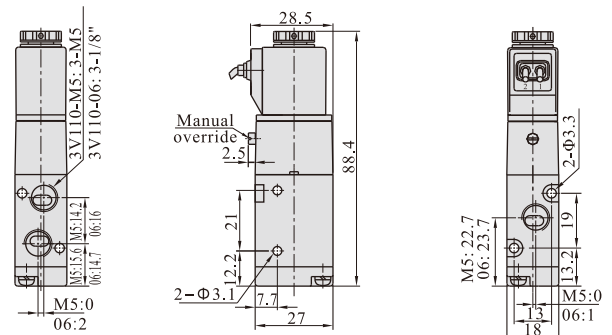

3V120(Terminal)

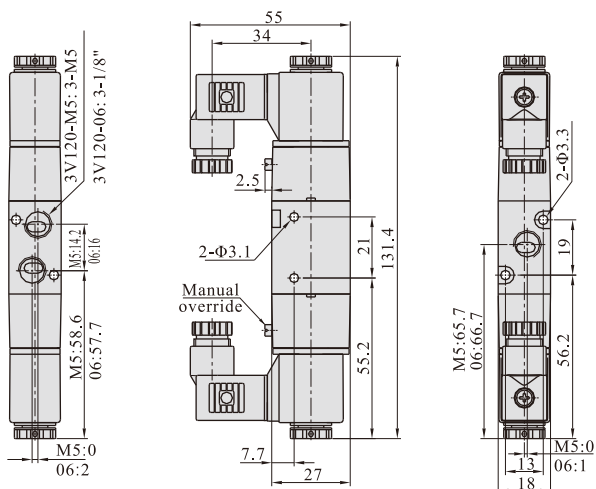

3V120(Grommet)

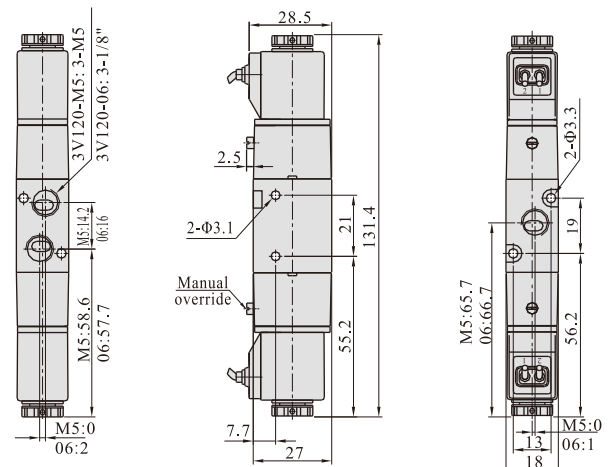

3V200 Series



Specification

Model	3V210-06	3V220-06	3V210-08	3V220-08
Fluid	Air(to be filtered by 40 μm filter element)			
Acting	Internal pilot or external pilot			
Port size [Note 1]	In=Out=1/8"		In=Out=1/4"	
Orifice size	14.0mm ² (Cv=0.78)		16.0mm ² (Cv=0.89)	
Valve type	3 port 2 position			
Lubrication [Note 2]	Not required			
Operating pressure	0.15~0.8MPa(21~114psi)			
Proof pressure	1.2MPa(175psi)			
Temperature	-20~70°C			
Material of body	Aluminum alloy			

[Note 1] PT thread, G thread and NPT thread are available.

[Note 2] Once lubricated air is used, continue with same medium to optimise valve life span. Lubricants like ISO VG32 or equivalent are recommended.

Symbol

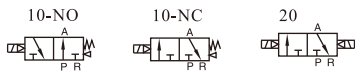

Product feature

1. Pilot-oriented mode: Internal pilot or external pilot.
2. Structure in sliding column mode: good tightness and sensitive reaction.
3. Double control solenoid valves have memory function.
4. Internal hole adopts special processing technology which has little attrition friction, low start pressure and long service life.
5. No need to add oil for lubrication.
6. Affiliated manual devices are equipped to facilitate installation and debugging.
7. Several standard voltage grades are optional.
8. Integrate with the manifold to save installation space.

Coil specification

Item	specification				
Standard voltage	AC220V	AC110V	AC24V	DC24V	DC12V
Scope of voltage	AC: ±15% DC: ±10%				
Power consumption	4.5VA	4.5VA	5.0VA	3.0W	3.0W
Protection	IP65(DIN40050)				
Temperature classification	B Class				
Electrical entry	Terminal, Grommet				
Activating time	0.05 sec and below				
Max. frequency [Note1]	5 cycle/sec				

[Note 1] The maximum actuation frequency is in the no-load state.

Ordering code

3V 2 10 08 NO A □ □							
① Model	② Code	③ Valve type	④ Port size	⑤ Acting type	⑥ Standard voltage	⑦ Electrical entry	⑧ Thread type
3V: Solenoid valve (3/2 way)	2: 200 Series	10: Single solenoid	06: 1/8" 08: 1/4"	NC: Normally closed NO: Normally opened	A: AC220V B: DC24V C: AC110V E: AC24V F: DC12V	Blank: Terminal I: Grommet	Blank: PT G: G T: NPT
		20: Double solenoid		No this code			

Please refer to 26 for manifold specification and the order way.

Flow chart

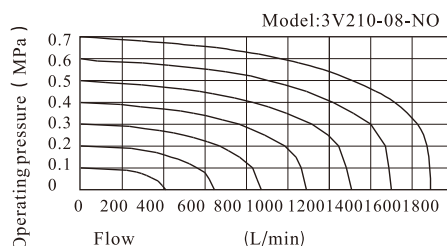

3V200 Series

Inner structure

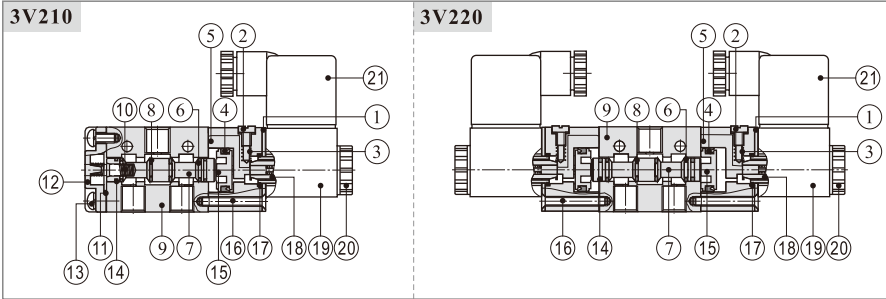

No.	Item	No.	Item	No.	Item
1	Fixed plate	8	O-ring	15	Piston
2	Manual override	9	Body	16	Pilot screw
3	Override spring	10	Spool spring	17	O-ring
4	Piston O-ring	11	Bottom cover gasket	18	Armature
5	Pilot body	12	Bottom cover	19	Coil
6	Spool packing	13	Screw	20	Coil net
7	Spool	14	Wear ring	21	Connector

Dimensions

3V210(Terminal)

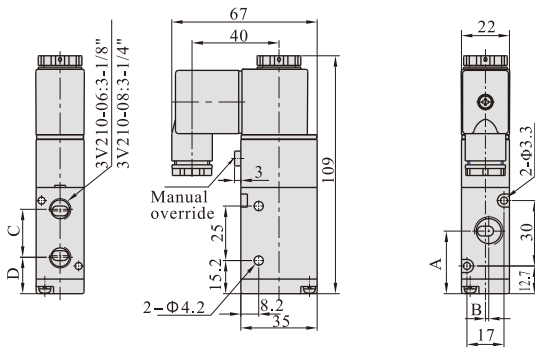

Item\Model	3V210-06	3V210-08
A	27.7	28.7
B	0	1.5
C	22	22.5
D	16.7	16.5

3V210(Grommet)

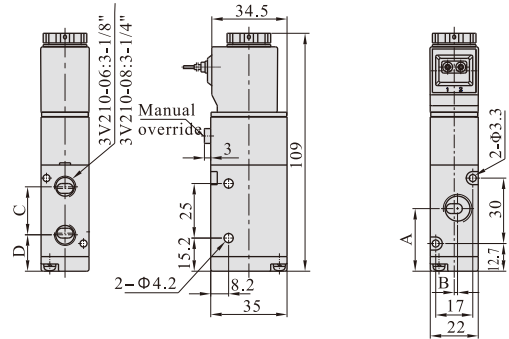

Item\Model	3V210-06	3V210-08
A	27.7	28.7
B	0	1.5
C	22	22.5
D	16.7	16.5

3V220(Terminal)

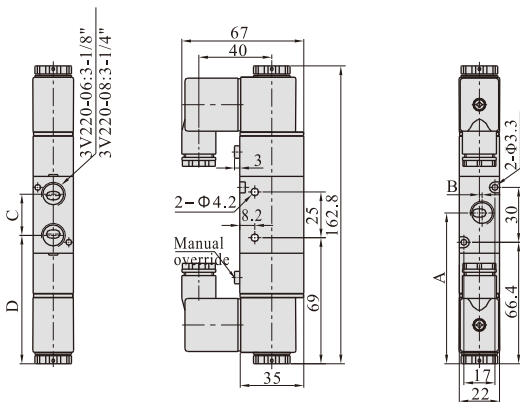

Item\Model	3V220-06	3V220-08
A	81.4	82.4
B	0	1.5
C	22	22.5
D	70.4	70.2

3V220(Grommet)

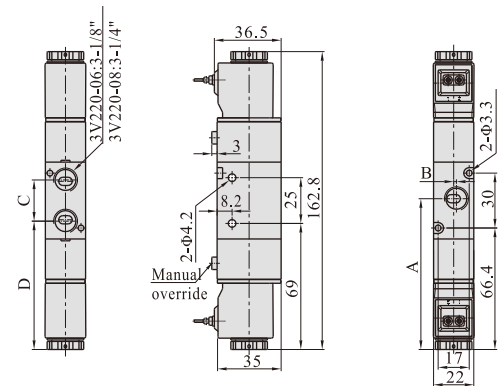

Item\Model	3V220-06	3V220-08
A	81.4	82.4
B	0	1.5
C	22	22.5
D	70.4	70.2



Specification

Model	3V310-08	3V320-08	3V310-10	3V320-10
Fluid	Air(to be filtered by 40 μm filter element)			
Acting	Internal pilot or external pilot			
Port size [Note 1]	In=Out=1/4"		In=Out=3/8"	
Orifice size	25.0mm ² (Cv=1.39)		30.0mm ² (Cv=1.67)	
Valve type	3 port 2 position			
Lubrication [Note2]	Not required			
Operating pressure	0.15~0.8MPa(21~114psi)			
Proof pressure	1.2MPa(175psi)			
Temperature	-20~70°C			
Material of body	Aluminum alloy			

[Note1] PT thread, G thread and NPT thread are available.

[Note2] Once lubricated air is used, continue with same medium to optimise valve life span. Lubricants like ISO VG32 or equivalent are recommended.

Symbol

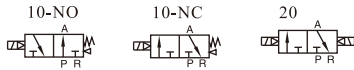

Product feature

- Pilot-oriented mode: Internal pilot or external pilot.
- Structure in sliding column mode: good tightness and sensitive reaction.
- Double control solenoid valves have memory function.
- Internal hole adopts special processing technology which has little attrition friction, low start pressure and long service life.
- No need to add oil for lubrication.
- Affiliated manual devices are equipped to facilitate installation and debugging.
- Several standard voltage grades are optional.
- Integrate with the manifold to save installation space.

Coil specification

Item	specification				
Standard voltage	AC220V	AC110V	AC24V	DC24V	DC12V
Scope of voltage	AC: ±15% DC: ±10%				
Power consumption	4.5VA	4.5VA	5.0VA	3.0W	3.0W
Protection	IP65(DIN40050)				
Temperature classification	B Class				
Electrical entry	Terminal, Grommet				
Activating time	0.05 sec and below				
Max. frequency [Note1]	5 cycle/sec				

[Note1] The maximum actuation frequency is in the no-load state.

Ordering code

3V 3 10 10 NO A □ □



① Model	② Code	③ Valve type	④ Port size	⑤ Acting type	⑥ Standard voltage	⑦ Electrical entry	⑧ Thread type
3V: Solenoid valve (3/2 way)	3: 300 Series	10: Single solenoid 20: Double solenoid	08: 1/4" 10: 3/8"	NC: Normally closed NO: Normally opened No this code	A: AC220V B: DC24V C: AC110V E: AC24V F: DC12V	Blank: Terminal I: Grommet	Blank: PT G: G T: NPT

Please refer to 26 for manifold specification and the order way.

Flow chart

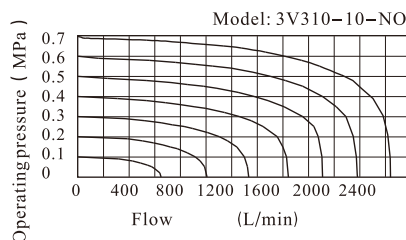

Solenoid valve(3/2 way)

3V300 Series

Inner structure

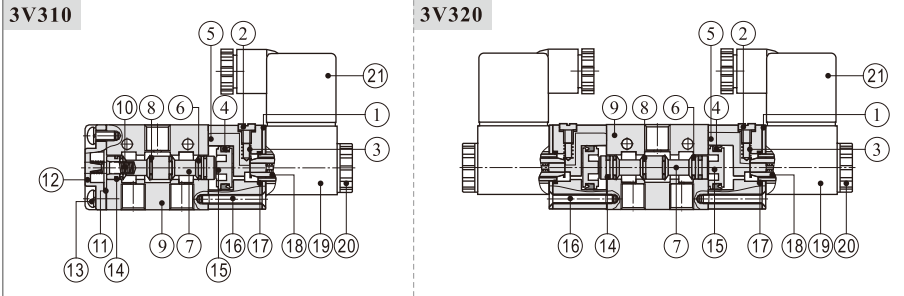

No.	Item	No.	Item	No.	Item
1	Fixed plate	8	O-ring	15	Piston
2	Manual override	9	Body	16	Pilot screw
3	Override spring	10	Spool spring	17	O-ring
4	Piston O-ring	11	Bottom cover gasket	18	Armature
5	Pilot body	12	Bottom cover	19	Coil
6	Spool packing	13	Screw	20	Coil net
7	Spool	14	Wear ring	21	Connector

Dimensions

3V310(Terminal)

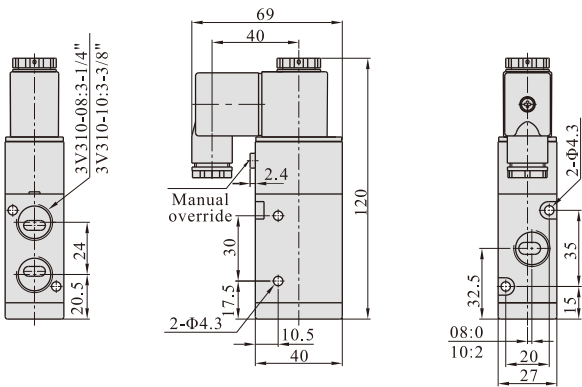

3V310(Grommet)

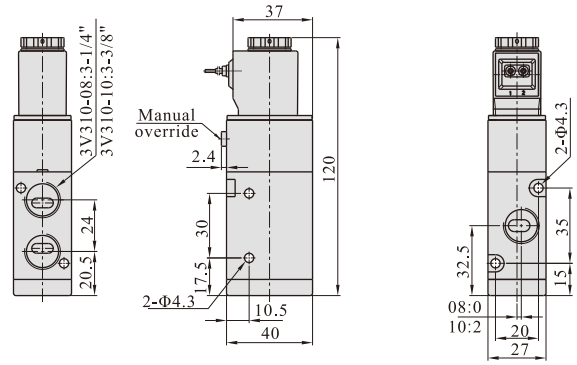

3V320(Terminal)

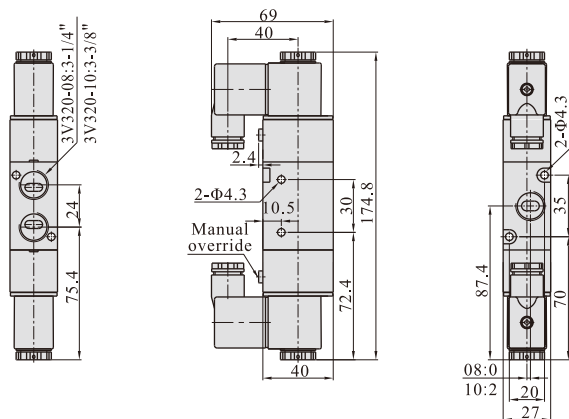

3V320(Grommet)

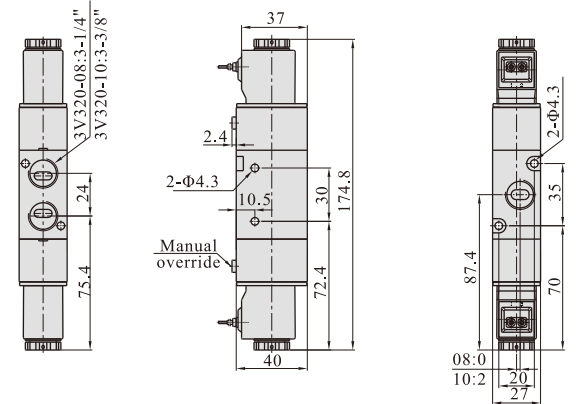

Manifold



Specification

Item\Manifold Model	100M	200M	300M
Fluid	Air(to be filtered by 40 μ m filter element)		
Temperature	-20~70°C		
Adaptable valve's series	3V100 Series	3V200 Series	3V300 Series

Product feature

1. It is available to integrate the direction control valves of the same series to form valve group to save space and cost.
2. It is easy to examine when there are faults owing to the unified air intake and exhaust and unified wiring.
3. Flexible combination and strong expansion capability can make any combination or expansion of the numbers of direction control valves that are connected.

Ordering code

Ordering code for manifold

3V100M 5F □

① ② ③

① Model	② Number of stations	③ Thread type
3V100M: 100 Series manifold	1F: 1 station	Blank: PT G: G T: NPT
3V200M: 200 Series manifold	2F: 2 station	
3V300M: 300 Series manifold	3F: 3 station	
	
	16F: 16 station	

Ordering code for blank plate

P-3V100M-R2

① ② ③

① Kits	② Model	③ Code
P: Kits	3V100M: 100Series manifold 3V200M: 200Series manifold 3V300M: 300Series manifold	R2: Blank plate for manifold

- [Note] 1. Ordering code contains the two parts of the manifold's and the blank plate's;
2. Manifold kits contains manifold, seal and screw.
3. Blank plate kits contains blank plate and screw.

Dimensions

With 3V solenoid valve

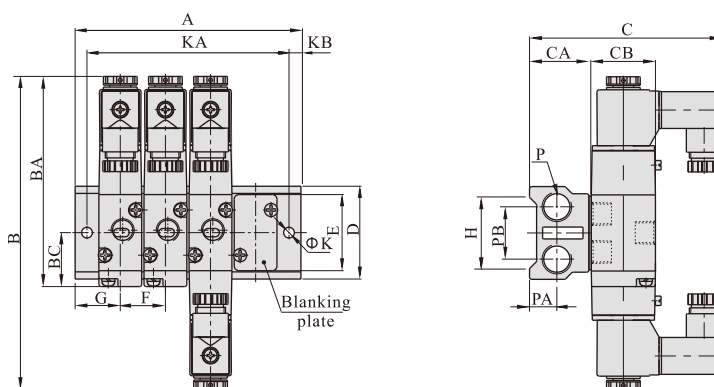

Model/Item	B	BA	BC	C	CA	CB	D	E	F	G	H	K	KB	P	PA	PB
3V100M	131.5	88.5	22.7	81	26	27	39	32	19	19	30	4.5	5	1/4"	11.5	22
3V200M	162.5	109	27.7	92.5	26	35	45	40	23	23	35	4.5	6	1/4"	11.5	25
3V300M	175	120	32.5	99	30	40	52	47	28	27	42	4.5	6	3/8"	13.5	28

Model/Item	A															
	1F	2F	3F	4F	5F	6F	7F	8F	9F	10F	11F	12F	13F	14F	15F	16F
3V100M	38	57	76	95	114	133	152	171	190	209	228	247	266	285	304	323
3V200M	46	69	92	115	138	161	184	207	230	253	276	299	322	345	368	391
3V300M	54	82	110	138	166	194	222	250	278	306	334	362	390	418	446	474

Model/Item	KA															
	1F	2F	3F	4F	5F	6F	7F	8F	9F	10F	11F	12F	13F	14F	15F	16F
3V100M	28	47	66	85	104	123	142	161	180	199	218	237	256	275	294	313
3V200M	34	57	80	103	126	149	172	195	218	241	264	287	310	333	356	379
3V300M	42	70	98	126	154	182	210	238	266	294	322	350	378	406	434	462