

## Product feature

1. Standard cylinder manufactured by our enterprise.
2. The seal of piston adopts heterogeneous two way seal structure. It's dimension is tight and it has the function of grease reservation.
3. It is tie rod cylinder. The cylinder barrel and front/rear cap is jointed by tie rods with high reliability.
4. Piston rod can be positioned in several positions in the whole action process.
5. The buffer adjustment of cylinder is smooth and steady.
6. Cylinders and mounting accessories with several specifications are optional.
7. The seal material with high temperature resistance is adopted to guarantee the normal operation of cylinder at 150°C.

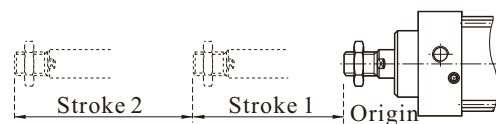

## Symbol



## Specification

Bore size(mm)	32	40	50	63	80	100
Acting type	Double acting					
Fluid	Air(to be filtered by 40μm filter element)					
Operating pressure	0.15~1.0MPa(22~145psi)(1.5~10.0bar)					
Proof pressure	1.5MPa(215psi)(15bar)					
Temperature	-20~70°C					
Speed range	30~800 mm/s					
Stroke tolerance	0~250 <sup>+1.0</sup> <sub>0</sub>		251~1000 <sup>+1.5</sup> <sub>0</sub>		1001~2000 <sup>+2.0</sup> <sub>0</sub>	
Cushion type	Variable cushion					
Cushion stroke	21			28		29
Port size [Note1]	G1/8	G1/4		G3/8		G1/2

[Note1] The standard thread type is G thread, Please control us for other thread type.

## Standard Stroke

Bore size(mm)	Standard stroke	Max.std stroke	Max. stroke
32	25 50 75 100 125 150 175 200 250 300 350 400 450 500	500	800
40	25 50 75 100 125 150 175 200 250 300 350 400 450 500	500	800
50	25 50 75 100 125 150 175 200 250 300 350 400 450 500	500	800
63	25 50 75 100 125 150 175 200 250 300 350 400 450 500	500	800
80	25 50 75 100 125 150 175 200 250 300 350 400 450 500	500	800
100	25 50 75 100 125 150 175 200 250 300 350 400 450 500	500	800

[Note] If the stroke is ≥800mm within the maximum stroke scope, it is treated as non-standard one.

Please contact the company for other special strokes.

## Ordering code

SCT- 63 × 50 × 50 - S - LB - H - □

① ② ③ ④ ⑤ ⑥ ⑦ ⑧

### ⑤ Magnet

Blank: Without magnet

S: With magnet

### ⑥ Mounting style

Blank: No accessories

LB: LB type

FA: FA type

FB: FB type

CA: CA type

CB: CB type

### ⑦ Seals material

Blank: NBR

H: Viton

T: TPU

### ⑧ Thread type

Blank: G thread

PT: PT thread

### ① Model

SCT : Double acting Multi-position type

### ② Bore size

32 40 50 63 80 100

### ③ Stroke I

Refer to stroke table for details

### ④ Stroke II

Refer to stroke table for details

## Inner structure and material of major parts

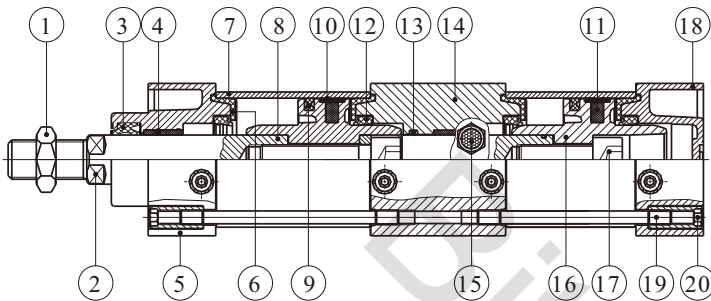

NO.	Item	Material
1	Rod nut	Carbon steel
2	Piston rod	Carbon steel with 20 μm chrome plated
3	Packing	TPU
4	Bushing	Wear resistant material
5	Front cover	Aluminum alloy
6	Cushing O-ring	TPU
7	Barrel	Aluminum alloy
8	Rod O-ring	NBR
9	Piston seal	NBR
10	Wear ring	Wear resistant material
11	Magnet	Plastic
12	Gasket	NBR
13	O-ring	NBR
14	Joint seat	Aluminum alloy
15	Silencer	
16	Piston	Aluminum alloy
17	Bolt	Carbon steel
18	Back cover	Aluminum alloy
19	Tie-rod	Carbon steel
20	Tie-rod nut	Carbon steel

## ■ Dimensions

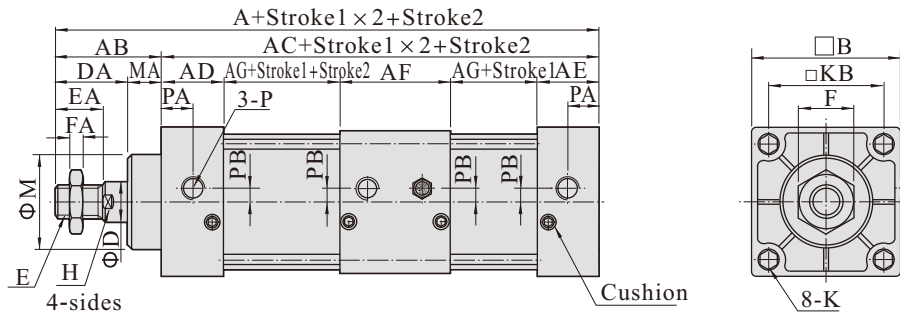

Bore size\Item	A	AB	AC	AD	AE	AF	AG	B	D	DA	E	EA	F	FA	H	K	KB	M	MA	P	PA	PB
32	233	47	186	27.5	27.5	55	38	45	12	32	M10×1.25	22	17	6	10	M6×1.0	33	28	15	G1/8	14	5.5
40	235	49	186	27.5	27.5	55	38	50	16	34	M12×1.25	24	17	7	13	M6×1.0	37	32	15	G1/4	15	6
50	243	57	186	27.5	27.5	55	38	62	20	42	M16×1.5	32	23	8	17	M6×1.0	47	38	15	G1/4	17	8.5
63	249	57	192	27.5	27.5	55	41	75	20	42	M16×1.5	32	23	8	17	M8×1.25	56	38	15	G3/8	15	9.5
80	296	75	221	33	33	73	41	94	25	54	M20×1.5	40	26	10	22	M10×1.5	70	47	21	G3/8	19.5	10
100	308	75	233	33	33	73	47	112	25	54	M20×1.5	40	26	10	22	M10×1.5	84	47	21	G1/2	16.5	11

Remark: The dimensions of magnet type cylinder are the same as non-magnet type cylinder.

## List for ordering code of accessories

Accessories Bore size	Mounting accessories					
	LB	FA\FB	CA	CB	TC	TCM1
32	F-SC32LB	F-SC32FA	F-SC32CA	F-SC32CB	F-SC32TC	F-SI40TCM1
40	F-SC40LB	F-SC40FA	F-SC40CA	F-SC40CB	F-SC40TC	F-SC40TCM1
50	F-SC50LB	F-SC50FA	F-SC50CA	F-SC50CB	F-SC50TC	F-SC40TCM1
63	F-SC63LB	F-SC63FA	F-SC63CA	F-SC63CB	F-SC63TC	F-SC40TCM1
80	F-SC80LB	F-SC80FA	F-SC80CA	F-SC80CB	F-SC80TC	F-SC80TCM1
100	F-SC100LB	F-SC100FA	F-SC100CA	F-SC100CB	F-SC100TC	F-SC80TCM1
125	F-SC125LB	F-SC125FA	F-SC125CA	F-SC125CB	F-SC125TC	F-SC125TCM1
160	F-SC160LB	F-SC160FA	F-SC160CA	F-SC160CB	F-SC160TC	F-SC160TCM1

Accessories Bore size	Knuckle				Sensor switch	
	I: I Knuckle	Y: Y Knuckle	F: F Knuckle	U: U Knuckle	CS1-G	DS1-G
32	F-M10X125I	F-M10X125Y	F-M10X125F	F-M10X125U	CMSSG	DS1-G
40	F-M12X125I	F-M12X125Y	F-M12X125F	F-M12X125U		
50	F-M16X150I	F-M16X150Y	F-M16X150F	F-M16X150U		
63	F-M16X150I	F-M16X150Y	F-M16X150F	F-M16X150U		
80	F-M20X150I	F-M20X150Y	F-M20X150F	F-M20X150U		
100	F-M20X150I	F-M20X150Y	F-M20X150F	F-M20X150U		
125	F-M27X200I	F-M27X200Y	F-M27X200F	F-M27X200U		
160	F-M36X200I	F-M36X200Y	F-M36X200F	F-M36X200U		

## Accessory selection

Accessories Cylinder model	Mounting accessories							Knuckle				Sensor switch	
	LB	FA	FB	CA	CB	TC	TCM1	I	Y	U	F	CS1-G	DS1-G
SC	Standard	●	●	●	●	●	●	●	●	●	●	×	×
	With magnet	●	●	●	●	●	●	●	●	●	●	●	●
SCD	Standard	●	●	×	×	×	●	●	●	●	●	×	×
	With magnet	●	●	×	×	×	●	●	●	●	●	●	●
SCJ	Standard	●	●	×	×	×	●	●	●	●	●	×	×
	With magnet	●	●	×	×	×	●	●	●	●	●	●	●
SCT	Standard	●	●	●	●	●	×	×	●	●	●	×	×
	With magnet	●	●	●	●	●	×	×	●	●	●	●	●

## Material of accessories

Accessories Bore size	Mounting accessories							Knuckle			
	LB	FA	FB	CA	CB	TC	TCM1	I	Y	F	U
32~100	□	●	●	◇	◇	◇	◇	□	□	□	□
125~160	◇	◇	◇	◇	◇	◇	◇	□	□	—	□

●—Aluminum alloy, ■—Cast steel, ◇—Nodular cast iron, □—Carbon steel.

## Accessories Dimensions

FA\FB type

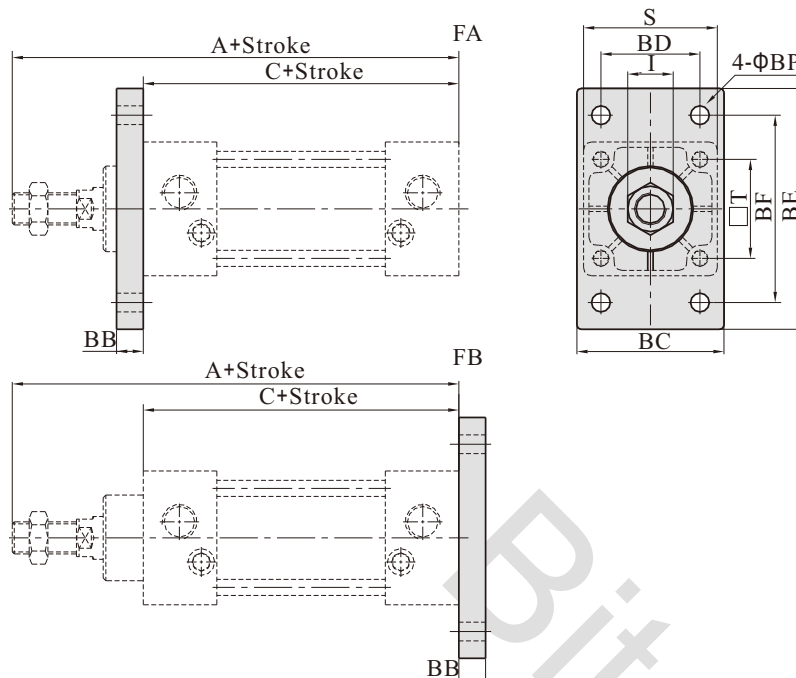

Bore size\Item	A	C	BB	BC	BD	BE	BF	BP	I	S	T
32	140	93	10	47	33	80	58	7	17	45	33
40	142	93	10	53	36	90	70	7	17	50	37
50	150	93	10	65	47	104	86	9	23	62	47
63	153	96	12	75	56	118	98	9	23	75	56
80	182	107	16	95	70	140	119	11	26	94	70
100	188	113	16	115	84	160	138	11	26	112	84
125	203	115	20	135	104	196	168	14	41	136	104
160	239	126	20	173	134	248	212	18	55	174	134

LB type

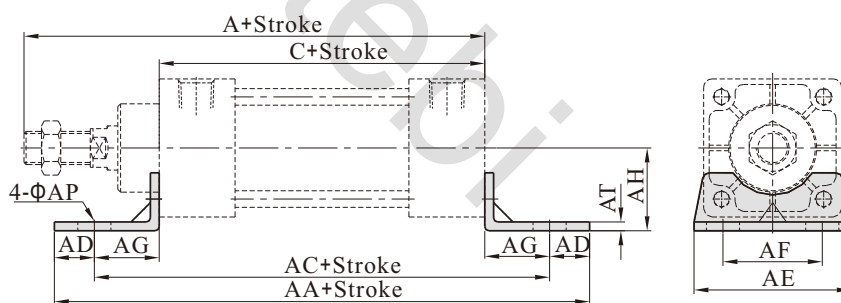

Bore size\Item	A	C	AA	AC	AD	AE	AF	AG	AH	AP	AT
32	140	93	153	134	9.5	50	33	20.5	28	9	3
40	142	93	169	140	14.5	57	36	23.5	30	12	3
50	150	93	173	149	12	68	47	28	36.5	12	3
63	153	96	184	158	13	80	56	31	41	12	3
80	182	107	199	167	16	97	70	30	49	14	4
100	188	113	209	173	18	112	84	30	57	14	4
125	203	115	221	185	18	136	104	35	70	17	6
160	239	126	246	206	20	174	134	40	91	17	8

## CA type

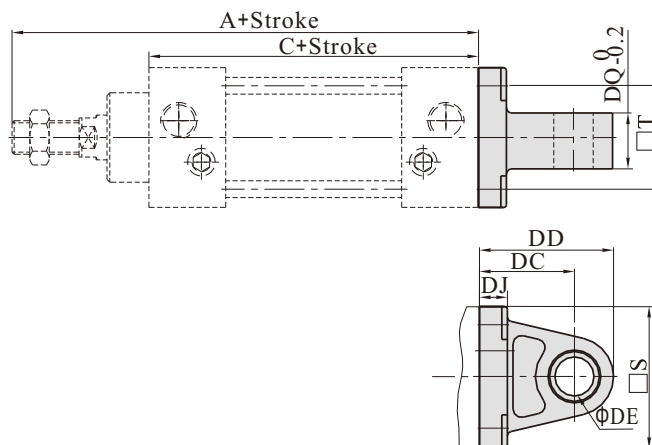

Bore size\Item	A	C	DC	DD	DE	DJ	DQ	S	T
32	140	93	34	44.5	12	9	16	45	33
40	142	93	34	45.5	14	9	20	49	37
50	150	93	34	46	14	10	20	61	47
63	153	96	34	46.5	14	10	20	74	56
80	182	107	48	64.5	20	14	32	93	70
100	188	113	48	65	20	14	32	111	84
125	203	115	32	52	20	17	31.7	135	104
160	239	126	40	68	28	19.5	39.7	173	134

## CB type

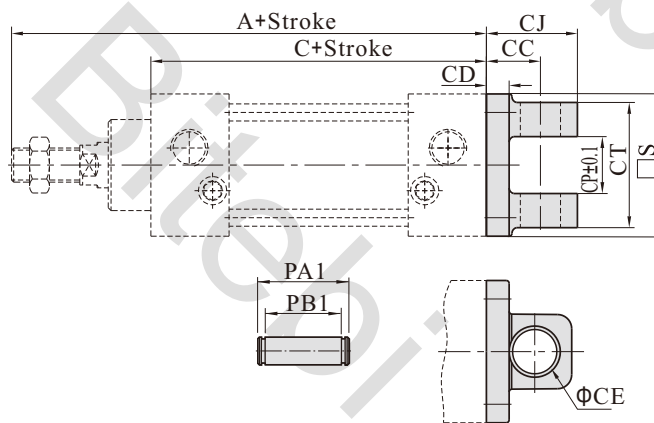

Bore size\Item	A	C	S	CC	CD	CE	CJ	CP	CT	PA1	PB1
32	140	93	45	19	9	12	29.5	16.3	32	39	32.8
40	142	93	49	19	9	14	30.5	20.3	44	51	44.8
50	150	93	61	19	10	14	31	20.3	52	59	52.8
63	153	96	74	19	10	14	31.5	20.3	52	59	52.8
80	182	107	93	32	14	20	48.5	32.3	64	73	64.8
100	188	113	111	32	14	20	49	32.3	64	73	64.8
125	203	115	135	32	14	20	52	32.1	64	73	64.8
160	239	126	173	40	15	28	68	40.1	80	90.2	80.8

## TC type

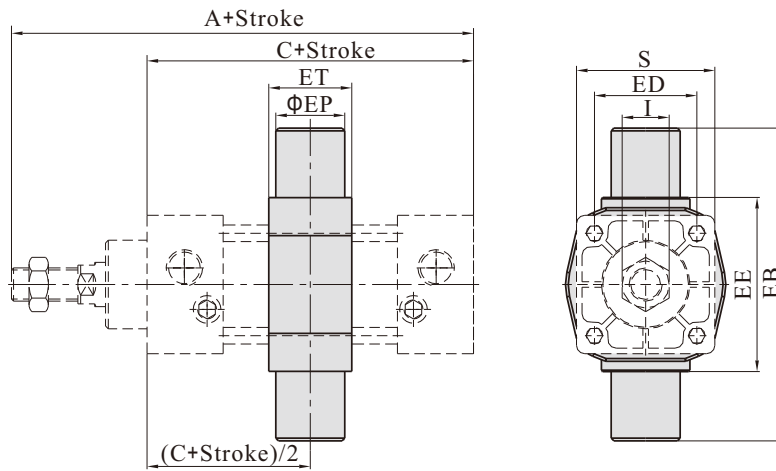

Bore size\Item	A	C	EB	ED	EE	EP	ET	I	S
32	140	93	87	33	55	16	22	17	45
40	142	93	113	37	63	25	28	17	50
50	150	93	126	47	76	25	28	23	62
63	153	96	138	56	88	25	30	23	75
80	182	107	164	70	114	25	32	26	94
100	188	113	182	84	132	25	38	26	112
125	203	115	208	104	158	25	40	41	136
160	239	126	272	134	200	36	46	55	174

[Note] The installation position of the accessories can not be adjusted arbitrarily.

## TCM1 type

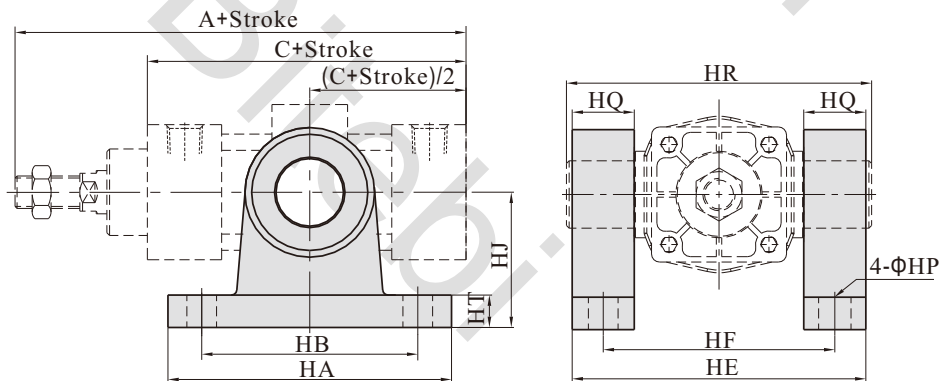

Bore size\Item	A	C	HA	HB	HE	HF	HP	HQ	HR	HT	HJ
32	140	93	100	75	90	71	12	16	87	11	54
40	142	93	103	80	109	86	11	23	113	12	50
50	150	93	103	80	122	99	11	23	126	12	50
63	153	96	103	80	134	111	11	23	138	12	50
80	182	107	110	85	160	137	13	23	164	12	70
100	188	113	110	85	178	155	13	23	182	12	70
125	203	115	145	105	211	183	18	25	208	20	85
160	239	126	185	140	272	236	22	36	272	25	130

[Note] The installation position of the accessories can not be adjusted arbitrarily.