

# Slide table cylinder(Cross roller type)

**BITEBI®**

HLS、HLSL Series

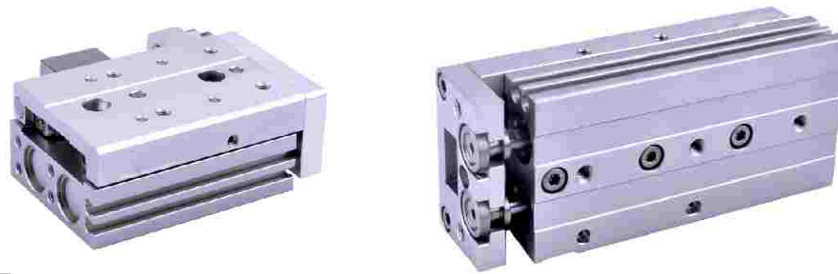

## Symbol



## Specification

Bore size(mm)	6	8	12	16	20	25
Acting type	Double acting					
Fluid	Air(to be filtered by 40 μ m filter element)					
Operating pressure	0.15~0.7MPa(22~100psi)(1.5~7.0bar)					
Proof pressure	1.2MPa(175psi)(12.0bar)					
Temperature °C	-20~70					
Speed range mm/s	50~500					
Stroke tolerance	Stroke ≤ 100      Stroke > 100					
Cushion type	Bumper(Both ends)、Shock absorber					
Sensor switches	CMSH、DMSH(S)					
Port size [Note1]	M5 × 0.8				1/8"	

[Note1] PT thread, G thread, NPT thread are available.

## Stroke

Bore size (mm)	Standard stroke (mm)	Max.std stroke
6	10 20 30 40 50	50
8	10 20 30 40 50 75	75
12	10 20 30 40 50 75 100	100
16	10 20 30 40 50 75 100 125	125
20	10 20 30 40 50 75 100 125 150	150
25	10 20 30 40 50 75 100 125 150	150

[Note] Consult us for non-standard stroke.

## Criteria for selection: Cylinder thrust

Unit: Newton(N)

Bore size	Rod size	Acting type	Pressure area(mm <sup>2</sup> )	Operating pressure(MPa)						
				0.2	0.3	0.4	0.5	0.6	0.7	
6	3	Double acting	Push-side	42	8	13	17	21	25	29
			Pull-side	57	11	17	23	29	34	40
8	4	Double acting	Push-side	75	15	23	30	38	45	53
			Pull-side	101	20	30	40	51	61	71
12	6	Double acting	Push-side	170	34	51	68	85	102	119
			Pull-side	226	45	68	90	113	136	158
16	8	Double acting	Push-side	302	60	91	121	151	181	211
			Pull-side	402	80	121	161	201	241	281
20	10	Double acting	Push-side	471	94	141	188	236	283	330
			Pull-side	628	126	188	251	314	377	440
25	12	Double acting	Push-side	756	151	227	302	378	454	529
			Pull-side	982	186	295	393	491	589	687

# Slide table cylinder(Cross roller type)

**BITEBI®**

HLS、HLSL Series

## Ordering code

**HLS 20 × 30 S AS □**

① ② ③ ④ ⑤ ⑥

### ① Model

HLS: Slide table cylinder  
(Double acting type)  
(Cross roller type)

HLSL: Symmetrical slide  
table cylinder  
(Double acting type)  
(Cross roller type)

### ② Bore Size

6 8 12  
16 20 25

### ③ Stroke

Refer to stroke table for details

### ④ Magnet

S: With magnet

### ⑥ Thread type [Note2]

Blank: PT  
G: G  
T: NPT

### ⑤ Adjuster option [Note1]

Blank: Without adjuster(Basic type)  
A: Adjustable rubber stopper(Both ends)  
B: Shock absorber(Both ends)  
AS: Adjustable rubber stopper(Extension)  
BS: Shock absorber(Extension)  
AF: Adjustable rubber stopper(Retraction)  
BF: Shock absorber(Retraction)

[Note1] B type, BS type, BF type are unavailable  
for bore size of  $\Phi 6$ .

[Note2] When the thread is standard,  
the code is blank.

## Inner structure and material of major parts

Basic type

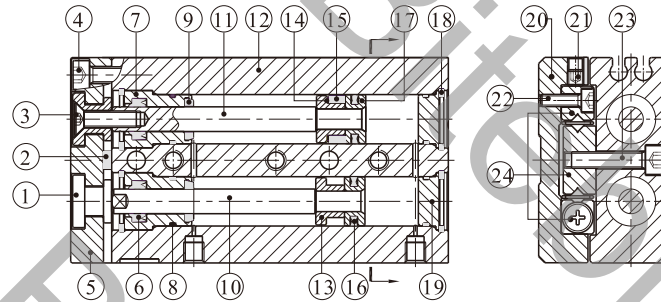

NO.	Item	Material	NO.	Item	Material
1	Floating joint	Carbon steel	13	Magnet holder	Brass
2	Bumper	TPU	14	Magnet washer	NBR
3	Screw	Carbon steel	15	Magnet	Sintered metal(Neodymium-iron-boron)
4	Screw	Carbon steel	16	Piston seal	NBR
5	Fixing plate	Aluminum alloy	17	Piston	Brass
6	Rod seal	NBR	18	C clip	Spring steel
7	Front cover	Aluminum alloy	19	Back cover	Aluminum alloy
8	O-ring	NBR	20	Slide table	Aluminum alloy
9	Bumper	TPU	21	Nut	Carbon steel
10	Piston rod A	Carbon steel	22	Screw	Carbon steel
11	Piston rod B	Stainless steel	23	Screw	Carbon steel
12	Body	Aluminum alloy	24	Slide guidecombination	Subassembly

## Model Selection Method

Please select compact cylinder's type according to following procedure, and cross reference with data sheets.

### A) Operating conditions(According to mounting position and work form)

1. Model used(Bore size, Stroke)
2. Type of cushion(Bumper, Shock absorber)
3. Mounting position of work(Top, front)
4. Mounting direction(Axial, Vertical)
5. Average speed  $V_a$ (mm/s)
6. Applied load  $W$ (N)

Explain:  $L_1$  is the distance of load's center beyond the end plank's plane.

If load's center is not beyond the end plank's plane,  $L_1$  is negative.

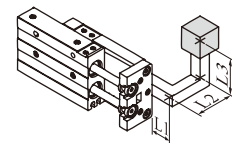
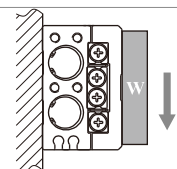
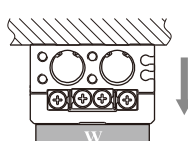
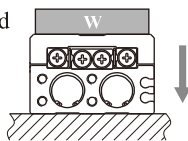

Fig. 1: Applied load



### B) Kinetic energy check

1. Calculate kinetic energy of load E(J)	$E = \frac{1}{2} \times \frac{W}{g} \times \left( \frac{1.4 \times V_a}{1000} \right)^2$
2. Calculate allowable kinetic energy Ea(J)	$E_a = K \times E_{max}$ K: Mounting work coefficient (Fig 2) E <sub>max</sub> : Maximum allowable kinetic energy (Table 1)
3. Check that kinetic energy of load doesn't exceed allowable kinetic energy: $E \leq E_a$	

### C) Load check

1. Calculate allowable applied load Wa (N)	$W_a = K \times \beta \times W_{max}$ K: Mounting work coefficient (Fig 2) W <sub>max</sub> : Maximum allowable applied load (Table 1) β: Applied load coefficient (Fig 3)
2. Check that load(W) doesn't exceed allowable applied load(Wa): $W \leq W_a$	

Fig 2: Mounting work coefficient (K)

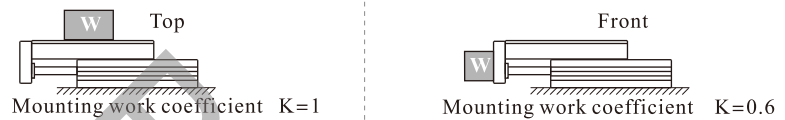
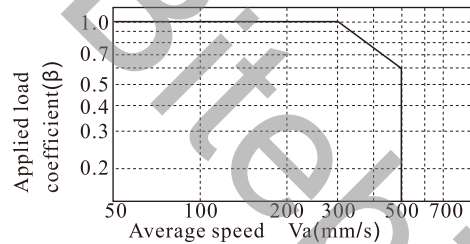

Fig 3: Applied load coefficient (β)



### D) Moment check

Horizontal	Vertical				
1. Calculate actual moment: Mp, Mpo, My, Myo, Mr, Mro (Nm)	1. Calculate actual moment: Mp, Mpo, My, Myo (Nm)				
Dynamic moment: $M_p = W \times (L1 + A) / 1000$ Static moment: $M_{po} = \frac{W \times (L1 + A)}{1000} + \frac{W \times a \times (L2 + B)}{1000 \times g}$	Dynamic moment: $M_p = W \times (L2 + B) / 1000$ Static moment: $M_{po} = \frac{W \times (L2 + B)}{1000} + \frac{W \times a \times (L2 + B)}{1000 \times g}$				
Dynamic moment: $M_r = W \times (C + L3) / 1000$ Static moment: $M_{ro} = (W \times a \times (C + L3)) / 1000g$	Dynamic moment: $M_y = W \times (C + L3) / 1000$ Static moment: $M_{yo} = \frac{W \times a \times (C + L3)}{1000g} + \frac{W \times (C + L3)}{1000}$				
Dynamic moment: $M_y = 0$ Static moment: $M_{yo} = (W \times a \times (C + L3)) / 1000g$	2. Check				
2. Check	<table border="1"> <tr> <td>Dynamic moment:</td> <td><math>\frac{M_p}{M_{p_{max}}} + \frac{M_y}{M_{y_{max}}} \leq 1</math></td> </tr> <tr> <td>Static moment:</td> <td><math>\frac{M_{po}}{M_{po_{max}}} + \frac{M_{yo}}{M_{yo_{max}}} \leq 1</math></td> </tr> </table>	Dynamic moment:	$\frac{M_p}{M_{p_{max}}} + \frac{M_y}{M_{y_{max}}} \leq 1$	Static moment:	$\frac{M_{po}}{M_{po_{max}}} + \frac{M_{yo}}{M_{yo_{max}}} \leq 1$
Dynamic moment:	$\frac{M_p}{M_{p_{max}}} + \frac{M_y}{M_{y_{max}}} \leq 1$				
Static moment:	$\frac{M_{po}}{M_{po_{max}}} + \frac{M_{yo}}{M_{yo_{max}}} \leq 1$				

Explain:  
 L1/L2/L3: The distance of load center to mount plane (Determined by actuality).  
 A/B/C: Correction value for center position distance of moment (Refer to table 2).  
 Mp<sub>max</sub>/My<sub>max</sub>/Mr<sub>max</sub>/Mpo<sub>max</sub>/Myo<sub>max</sub>/Mro<sub>max</sub>: Maximum allowable moment (Refer to table 2).  
 g: Acceleration of gravity (g=9.81m/s<sup>2</sup>).  
 a: Acceleration of inertia  
 (Bumper: a=1600 × (Va/1000)<sup>2</sup>, Shock absorber: a=400 × (Va/1000)<sup>2</sup>)  
 W: Load weight (Determined by actuality).

# Slide table cylinder(Cross roller type)

## HLS、HLSL Series

**Table 1:** Maximum allowable kinetic energy(E<sub>max</sub>)      Maximum allowable applied load(W<sub>max</sub>)

Model	Max. allowable kinetic energy      E <sub>max</sub> (J)			Max. allowable applied load W <sub>max</sub> (N)
	Basic type	Rubber stopper type	Shock absorber type	
HLS6	0.01	0.01	—	4
HLS8	0.024	0.024	0.048	8
HLS12	0.05	0.05	0.1	15
HLS16	0.1	0.1	0.2	30
HLS20	0.13	0.13	0.26	40
HLS25	0.22	0.22	0.44	70

**Table 2:** Maximum allowable moment(Nm),  
Correction value for center position distance of moment(mm)

Note: Symbol and unit

Bore size	Stroke	Static moment			Dynamic moment			Correction value			Symbol	Item	Unit
		M <sub>po_max</sub>	M <sub>yo_max</sub>	M <sub>ro_max</sub>	M <sub>p_max</sub>	M <sub>y_max</sub>	M <sub>r_max</sub>	A	B	C			
6	10	3.3	3.8	2.6	0.7	0.7	0.6	27	7.3	16	A, B, C	Correction value for center position distance of moment	mm
	20	3.3	3.8	2.6	0.7	0.8	0.6	42			a	Acceleration of inertia	—
	30	3.3	3.8	2.6	0.7	0.8	0.6	52			E	Kinetic energy	J
	40	7.2	7.9	3.6	1.3	1.3	0.6	72			Ea	Allowable kinetic energy	J
	50	12.4	12.7	4.7	1.8	1.8	0.6	87			E <sub>max</sub>	Maximum allowable kinetic energy	J
8	10	10.1	9.1	8.8	2.5	2.5	2.0	32	8.5	20	g	Acceleration of gravity g=9.81	m/s <sup>2</sup>
	20	10.1	9.1	8.8	2.6	2.6	2.0	42			K	Mounting work coefficient	—
	30	10.1	9.1	8.8	2.8	2.8	2.0	57			L1, L2, L3	Overhang	mm
	40	12.4	10.8	10.1	3.4	3.4	2.3	72			M <sub>p</sub> , M <sub>y</sub> , M <sub>r</sub>	Dynamic moment (Pitch, Yaw, Roll)	Nm
	50	23.6	24.8	13.9	4.4	4.4	2.1	92			M <sub>po</sub> , M <sub>yo</sub> , M <sub>ro</sub>	Static moment (Pitch, Yaw, Roll)	Nm
	75	32.8	35.3	16.4	4.6	4.6	1.8	132			M <sub>p_max</sub> , M <sub>y_max</sub> , M <sub>r_max</sub>	Maximum allowable dynamic moment (Pitch, Yaw, Roll)	Nm
12	10	33.0	34.3	30.9	7.3	7.3	5.8	48	10	25	M <sub>po_max</sub> , M <sub>yo_max</sub> , M <sub>ro_max</sub>	Maximum allowable static moment (Pitch, Yaw, Roll)	Nm
	20	33.0	34.3	30.9	7.6	7.6	5.8	58			Va	Average speed	mm/s
	30	33.0	34.3	30.9	7.8	7.8	5.8	68			W	Applied load	N
	40	33.0	34.3	30.9	8.0	8.0	5.8	78			W <sub>max</sub>	Maximum allowable applied load	N
	50	53.4	49.6	39.7	9.8	9.8	5.8	88			β	Applied load coefficient	-
	75	78.8	71.9	48.6	14.2	14.2	6.8	125					
	100	78.8	71.9	48.6	14.7	14.7	6.8	160					
16	10	33.0	34.3	30.9	8.8	8.8	7.6	43	11	30			
	20	33.0	34.3	30.9	9.2	9.2	7.6	53					
	30	33.0	34.3	30.9	9.5	9.5	7.6	63					
	40	33.0	34.3	30.9	10.0	10.0	7.6	78					
	50	53.4	49.6	39.7	12.2	12.2	7.6	93					
	75	78.8	71.9	48.6	17.6	17.6	8.9	130					
	100	78.8	71.9	48.6	18.2	18.2	8.9	165					
	125	143.7	144.5	53.3	24.8	24.8	7.8	204					
20	10	60.1	50.5	72.8	14.5	14.5	15.2	47	16.5	35			
	20	60.1	50.5	72.8	15.2	15.2	15.2	57					
	30	60.1	50.5	72.8	15.7	15.7	15.2	67					
	40	60.1	50.5	72.8	16.3	16.3	15.2	82					
	50	60.1	50.5	72.8	16.6	16.6	15.2	92					
	75	169.3	154.3	114.4	41.2	41.2	22.0	136					
	100	169.3	154.3	114.4	42.8	42.8	22.0	176					
	125	169.3	154.3	114.4	43.6	43.6	22.0	205					
	150	267.5	286.6	145.6	49.0	49.0	20.5	249					
25	10	60.1	50.5	72.8	16.3	16.3	17.6	52	20.3	42			
	20	60.1	50.5	72.8	17.0	17.0	17.6	62					
	30	60.1	50.5	72.8	17.4	17.4	17.6	72					
	40	60.1	50.5	72.8	17.8	17.8	17.6	82					
	50	60.1	50.5	72.8	18.2	18.2	17.6	96					
	75	169.3	154.3	114.4	45.2	45.2	25.3	141					
	100	169.3	154.3	114.4	46.2	46.2	25.3	165					
	125	169.3	154.3	114.4	48.0	48.0	25.3	210					
	150	267.5	286.6	145.6	65.0	65.0	28.3	254					

### Installation and application

1. How to mount cylinder:

1.1) Cylinder can be mounted from 3 directions

Vertical Mounting(Body thread holes)

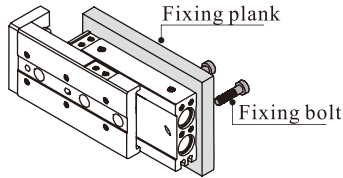

Vertical Mounting(Body through holes)

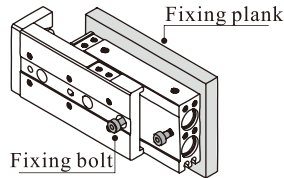

Axial Mounting  
(Body thread holes)

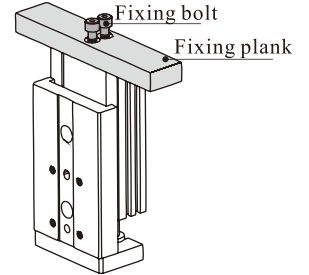

1.2) When mounting an compact slide cylinder, screws of appropriate length should be used and tightened properly within the maximum tightening torque. If screws are tightened beyond designed limits, malfunction may occur. If they are tightened insufficiently, it may result in sliding or falling off from its position.

Vertical Mounting(Body thread holes)

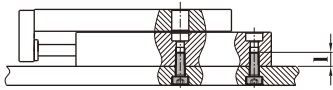

Model	Bolt used	Max. tightening torque (Nm)	Max. screw-in depth(mm)
HLS6	M4×0.7	2.1	8
HLS8	M4×0.7	2.1	8
HLS12	M5×0.8	4.4	10
HLS16	M6×1.0	4.4	10
HLS20	M6×1.0	7.4	12
HLS25	M8×1.25	18.0	16

Vertical Mounting(Body through holes)

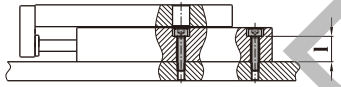

Model	Bolt used	Max. tightening torque (Nm)	Body depth(mm)
HLS6	M3×0.5	1.2	11.0
HLS8	M3×0.5	1.2	12.5
HLS12	M4×0.7	2.8	18.0
HLS16	M5×0.8	5.7	25.0
HLS20	M5×0.8	5.7	28.0
HLS25	M6×1.0	10.0	36.2

Axial Mounting(Body thread holes)

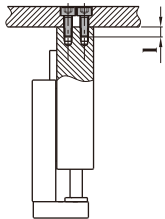

Model	Bolt used	Max. tightening torque (Nm)	Max. screw-in depth(mm)
HLS6	M2.5×0.45	0.5	3.5
HLS8	M3×0.5	0.9	4.0
HLS12	M4×0.7	2.1	6.0
HLS16	M5×0.8	4.4	7.0
HLS20	M5×0.8	4.4	8.0
HLS25	M6×1.0	7.4	10.0

2. Work Piece Mounting:

2.1) Work pieces can be mounted on 2 surfaces of the compact slide.

Front Mounting

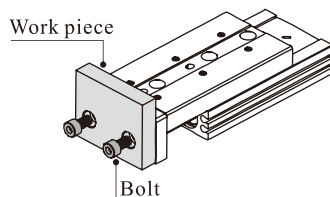

Top Mounting

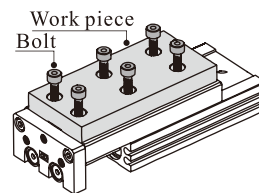

# Slide table cylinder(Cross roller type)

## HLS、HLSL Series

2.2) When mounting a work piece, tighten the bolts properly at a torque value within the limiting range. Use blots at least 0.5mm shorter than maximum thread depth to prevent bolts from contacting the guide block. If the bolts are too long, they hit the guide block and cause damage.

### Front Mounting

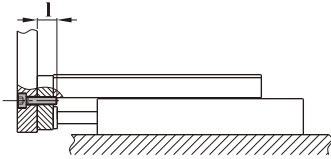

Model	Bolt used	Max. tightening torque (Nm)	Max. screw-in depth(mm)
HLS6	M3×0.4	0.9	5
HLS8	M4×0.7	2.1	6
HLS12	M5×0.8	4.4	8
HLS16	M6×1.0	7.4	10
HLS20	M6×1.0	7.4	13
HLS25	M8×1.25	18.0	15

### Top Mounting

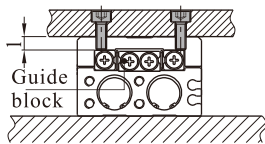

Model	Bolt used	Max. tightening torque (Nm)	Max. screw-in depth(mm)
HLS6	M3×0.5	0.9	4.0
HLS8	M3×0.5	0.9	5.0
HLS12	M4×0.7	2.1	5.5
HLS16	M5×0.8	4.4	6.0
HLS20	M5×0.8	4.4	10.0
HLS25	M6×1.0	7.4	13.0

2.3) Since the table is supported by the linear guide, take care not to apply strong impact or large moment to the guide section.  
 2.4) Hold the slide when fastening work pieces to it with bolts, If the body is held while tightening bolts, excessive moment may damage guide section.

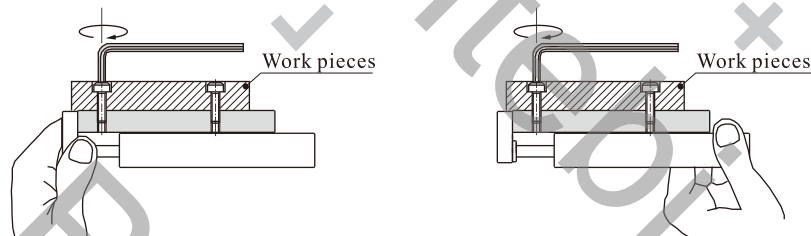

3. About shock absorber:  
 3.1) Shock absorbers are expendable. Promptly replace them when energy absorbing capacity decreases.  
 3.2) Never turn or adjust the screws on bottom of the shock absorber body. The screws are not for adjusting. Otherwise would cause oil leakage.  
 3.3) Follow the table for tightening torque of shock absorber to lock nuts.

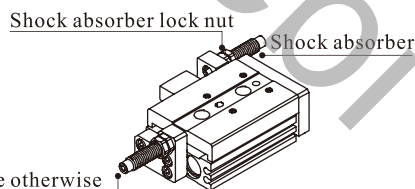

Model	Shock absorber	Tightening torque
HLS6	Without shock absorber	
HLS8	ACA0806-1N	1.67(Nm)
HLS12	ACA0806-1N	1.67(Nm)
HLS16	ACA1007-1N	3.14(Nm)
HLS20	ACA1210-1N	3.14(Nm)
HLS25	ACA1412-1N	10.8(Nm)

The screws are not adjustable otherwise would cause oil leakage.

4. How to mount sensor switch:  
 4.1) HLS Series are all with magnet. The matching sensor switches are CMSH、DMSH(S) series.  
 4.2) Maintain a minimum spacing of at least 3mm if two compact cylinders are used side by side in order to avoid malfunction.

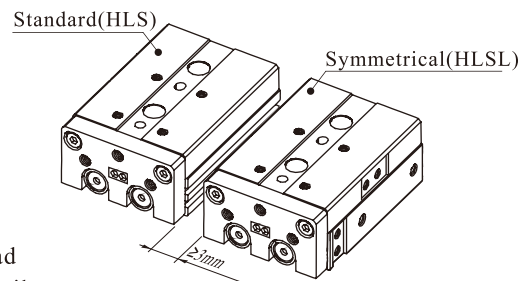

5. Make sure to connect the compact cylinder to speed controller at the meter-out side, and the speed of compact cylinder must below 500mm/s.  
 6. Don't apply a load beyond the range of the operation limits. Different load or torque will cause different deflection to table, please see below for details.

# Slide table cylinder(Cross roller type)

## HLS、HLSL Series

### 6.1) Table deflection due to pitch moment:

Table deflection (arrow) when a load acts upon the section marked with the arrow at the full stroke of the compact slide.

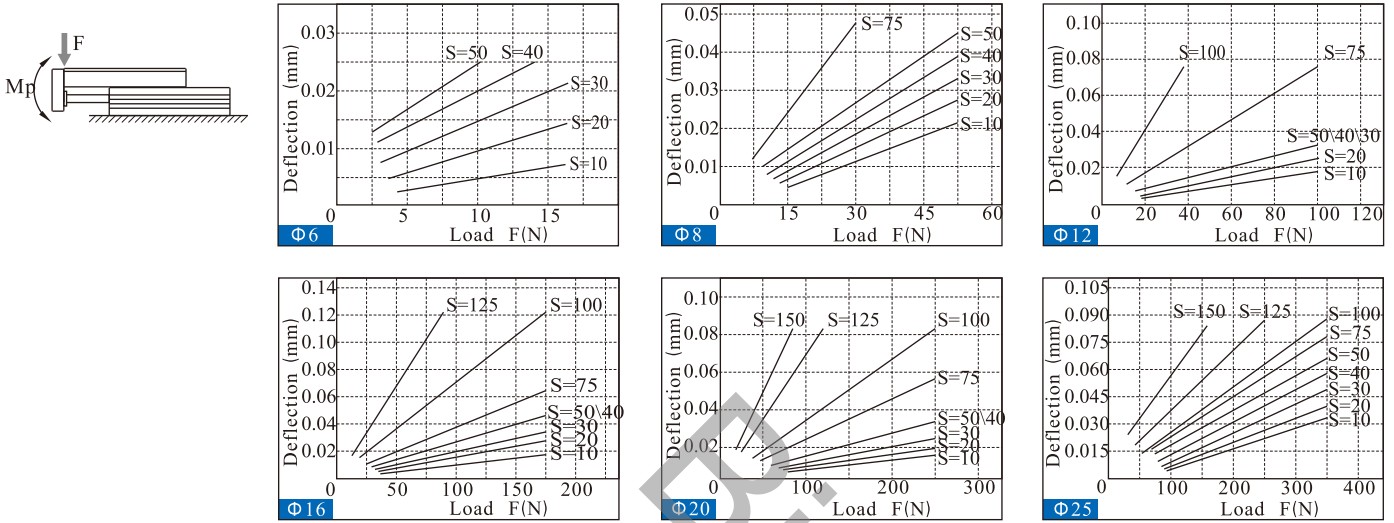

### 6.2) Table deflection due to yaw moment:

Table deflection (arrow) when a load acts upon the section marked with the arrow at the full stroke of the compact slide.

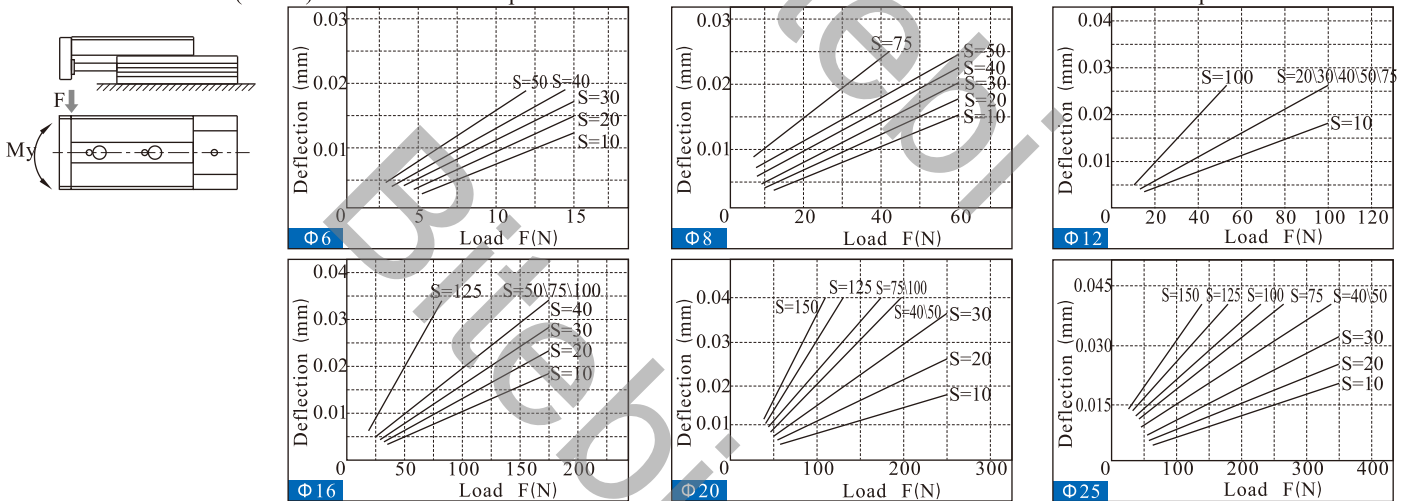

### 6.3) Table deflection due to roll moment:

Table deflects (A) when a load acts upon section F at the full stroke of the compact slide.

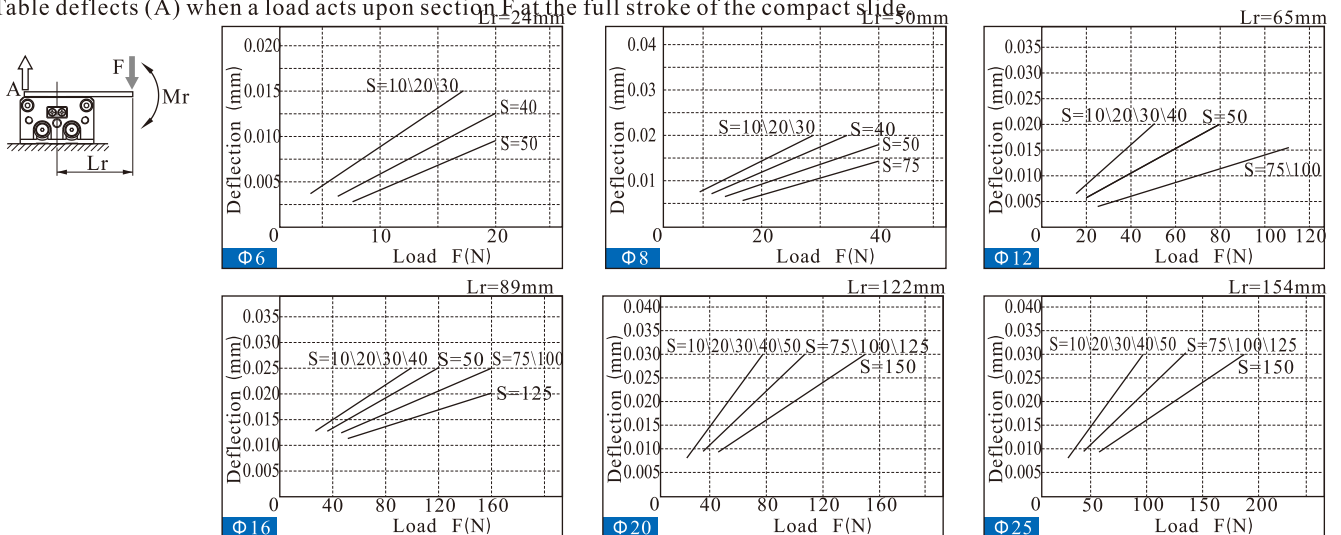

# Slide table cylinder(Cross roller type)

HLS、HLSL Series

## ■ Dimensions

HLS6

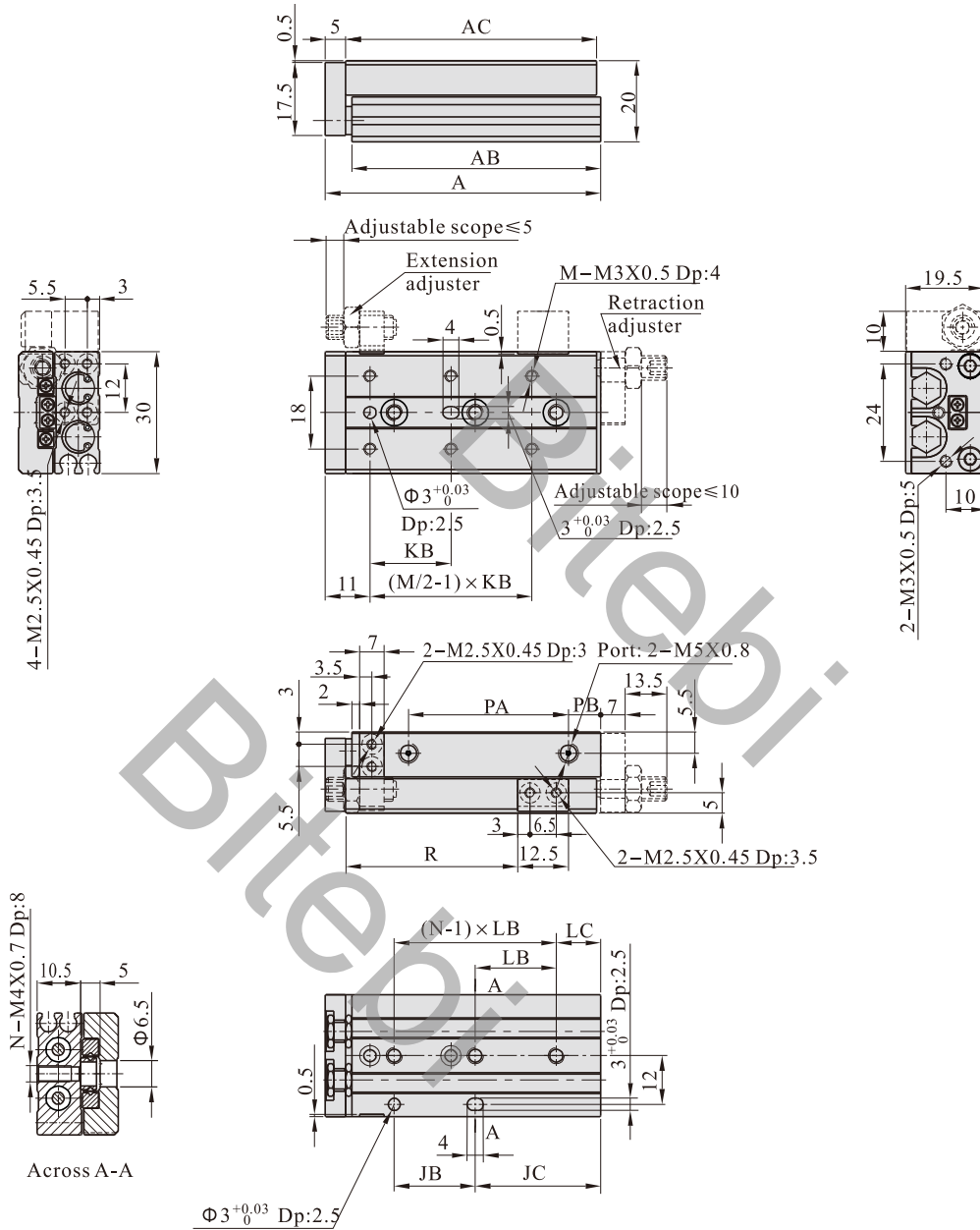

Stroke\Item	A	AB	AC	JB	JC	KB	LB	LC	M	N	PA	PB	R
10	48	41.5	42	20	11	20	25	6	4	2	19	8	21.5
20	58	51.5	52	20	21	30	35	6	4	2	28	9	31.5
30	68	61.5	62	20	31	20	20	11	6	3	39	8	41.5
40	90	83.5	84	30	43	28	30	13	6	3	51	18	51.5
50	106	99.5	100	48	41	38	24	17	6	4	61	24	61.5



# Slide table cylinder(Cross roller type)

HLS、HLSL Series

HLSL6

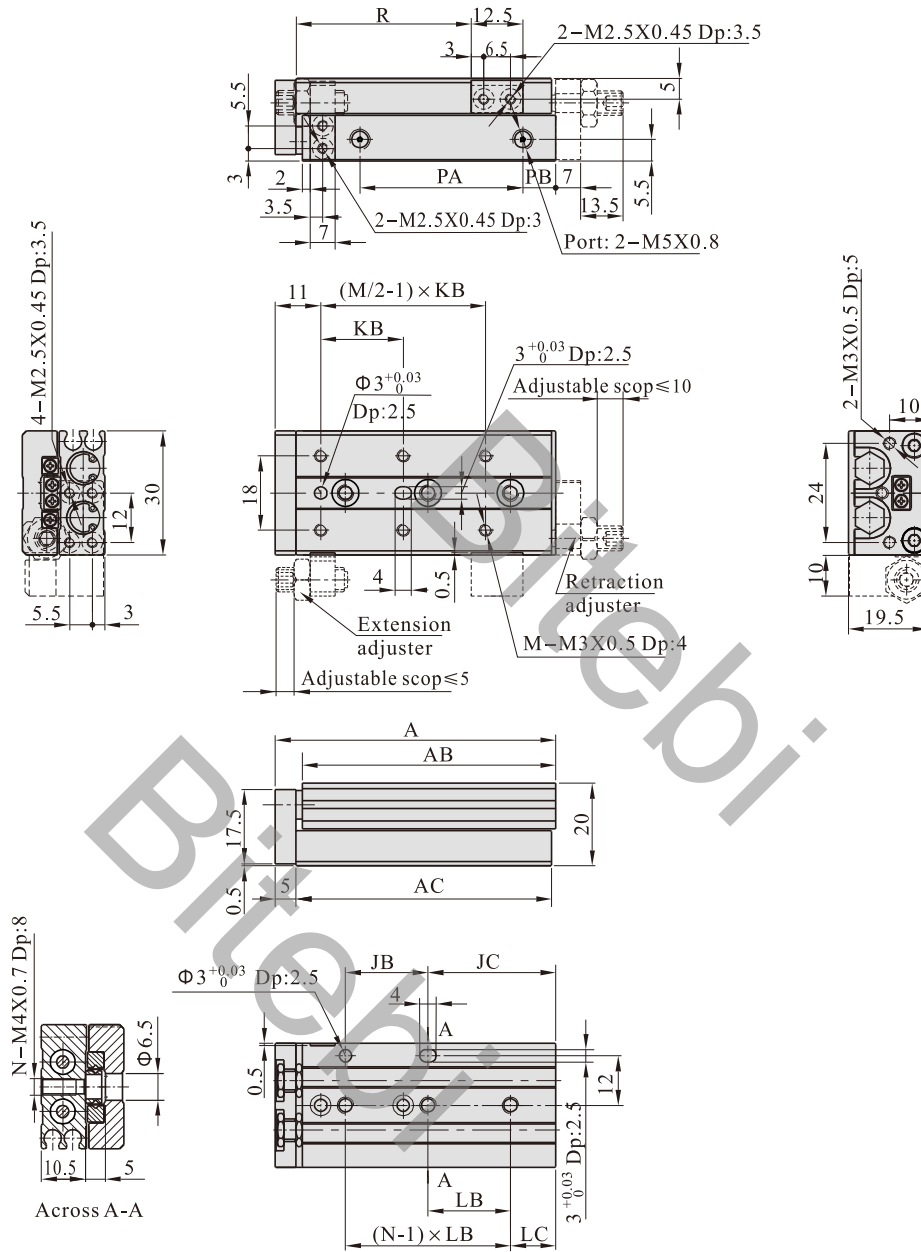

Stroke\Item	A	AB	AC	JB	JC	KB	LB	LC	M	N	PA	PB	R
10	48	41.5	42	20	11	20	25	6	4	2	19	8	21.5
20	58	51.5	52	20	21	30	35	6	4	2	28	9	31.5
30	68	61.5	62	20	31	20	20	11	6	3	39	8	41.5
40	90	83.5	84	30	43	28	30	13	6	3	51	18	51.5
50	106	99.5	100	48	41	38	24	17	6	4	61	24	61.5

# Slide table cylinder(Cross roller type)

HLS、HLSL Series

HLS8

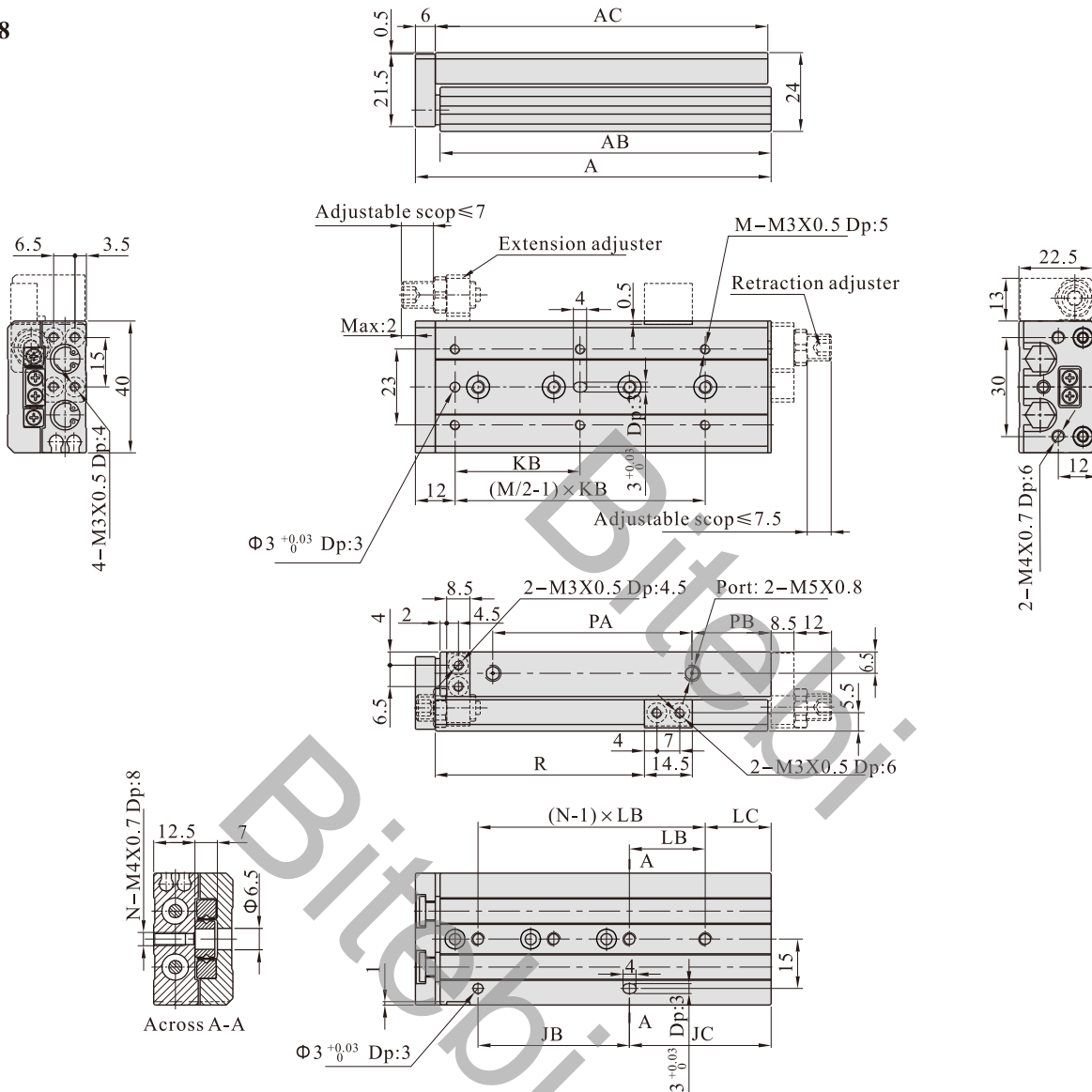

Stroke/Item	A	AB	AC	JB	JC	KB	LB	LC	M	N	PA	PB	R
10	56	48.5	49	20	17	25	28	9	4	2	19.5	12.5	23.5
20	61	53.5	54	30	12	25	30	12	4	2	30	7	33.5
30	72	64.5	65	20	33	40	20	13	4	3	41	7	43.5
40	90	82.5	83	28	43	50	28	15	4	3	56	10	53.5
50	108	100.5	101	46	43	38	23	20	6	4	68	16	63.5
75	158	150.5	151	56	83	50	28	27	6	5	94	40	88.5

## HLS8(With shock absorber)

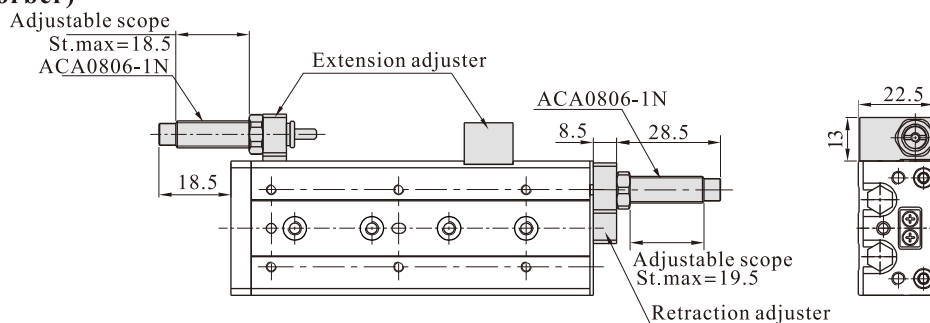

# Slide table cylinder(Cross roller type)

HLS, HLSL Series

HLSL8

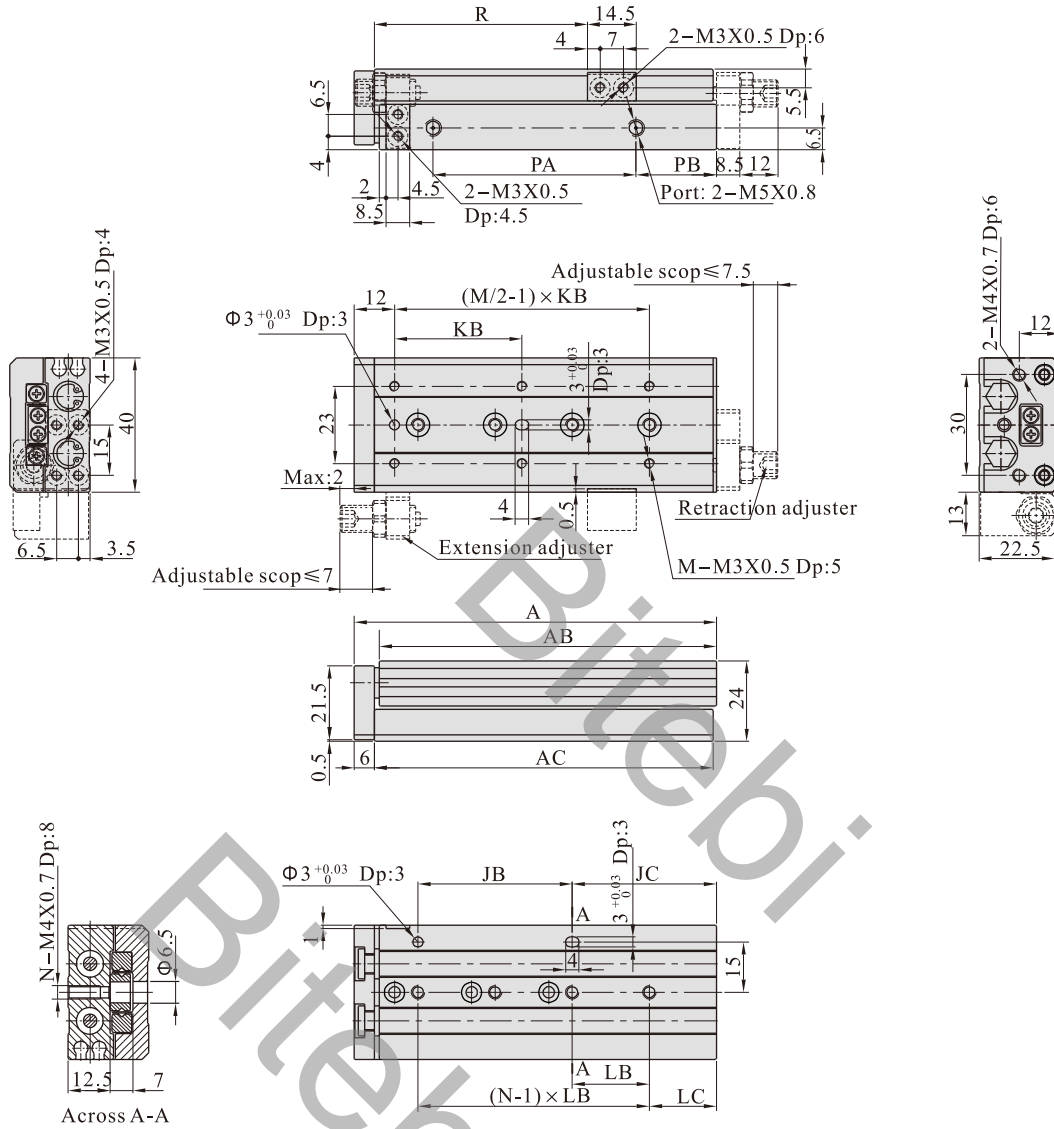

Stroke/Item	A	AB	AC	JB	JC	KB	LB	LC	M	N	PA	PB	R
10	56	48.5	49	20	17	25	28	9	4	2	19.5	12.5	23.5
20	61	53.5	54	30	12	25	30	12	4	2	30	7	33.5
30	72	64.5	65	20	33	40	20	13	4	3	41	7	43.5
40	90	82.5	83	28	43	50	28	15	4	3	56	10	53.5
50	108	100.5	101	46	43	38	23	20	6	4	68	16	63.5
75	158	150.5	151	56	83	50	28	27	6	5	94	40	88.5

## HLSL8(With shock absorber)

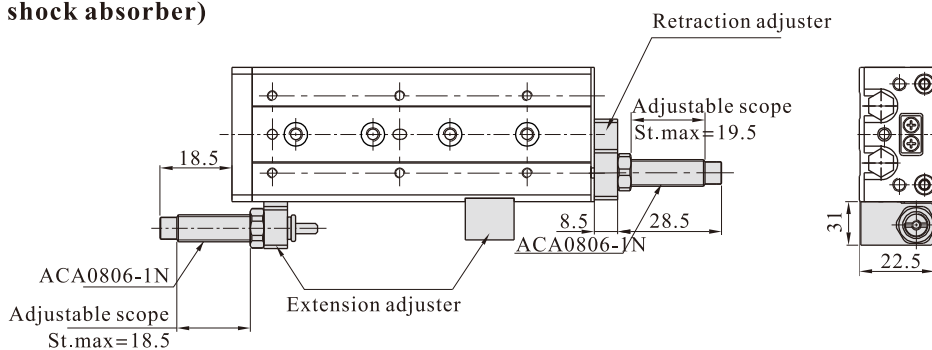

# Slide table cylinder(Cross roller type)

HLS、HLSL Series

HLS12

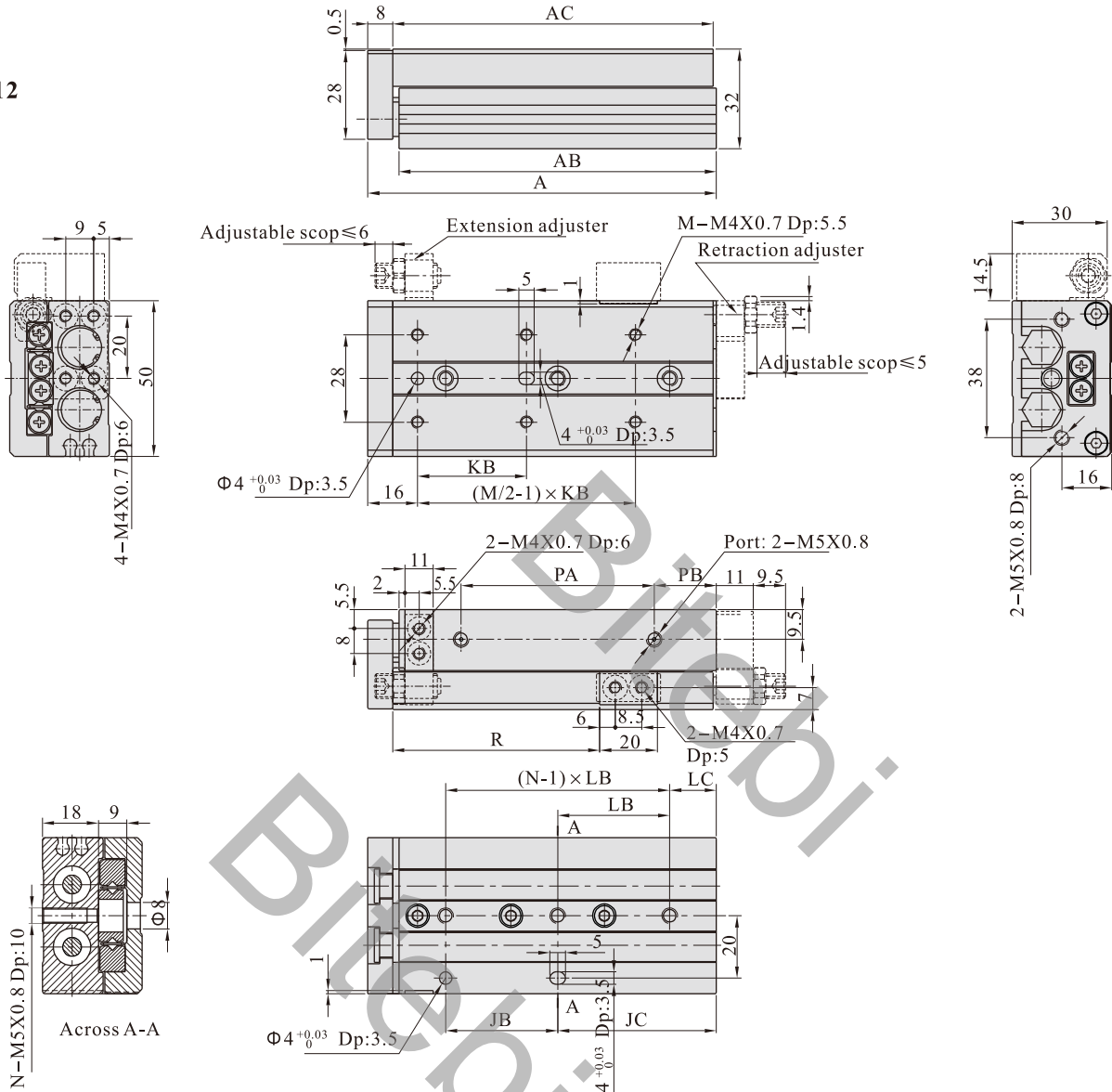

Stroke/Item	A	AB	AC	JB	JC	KB	LB	LC	M	N	PA	PB	R
10	80	70	71	40	15	35	40	15	4	2	39.5	10	25
20	80	70	71	40	15	35	40	15	4	2	39.5	10	35
30	80	70	71	40	15	35	40	15	4	2	39.5	10	45
40	92	82	83	25	42	50	25	17	4	3	51.5	10	55
50	112	102	103	36	51	35	36	15	6	3	61.5	20	65
75	158	148	149	72	61	55	36	25	6	4	87.5	40	90
100	212	202	203	76	111	65	38	35	6	5	131.5	50	115

## HLS12(With shock absorber)

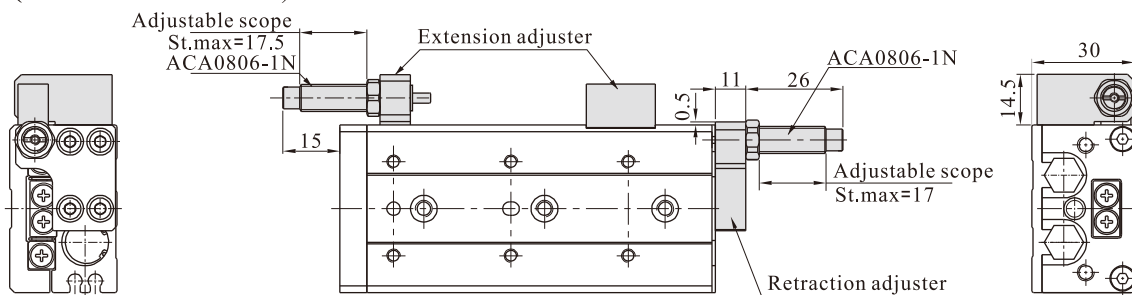

# Slide table cylinder(Cross roller type)

HLS、HLSL Series

HLSL12

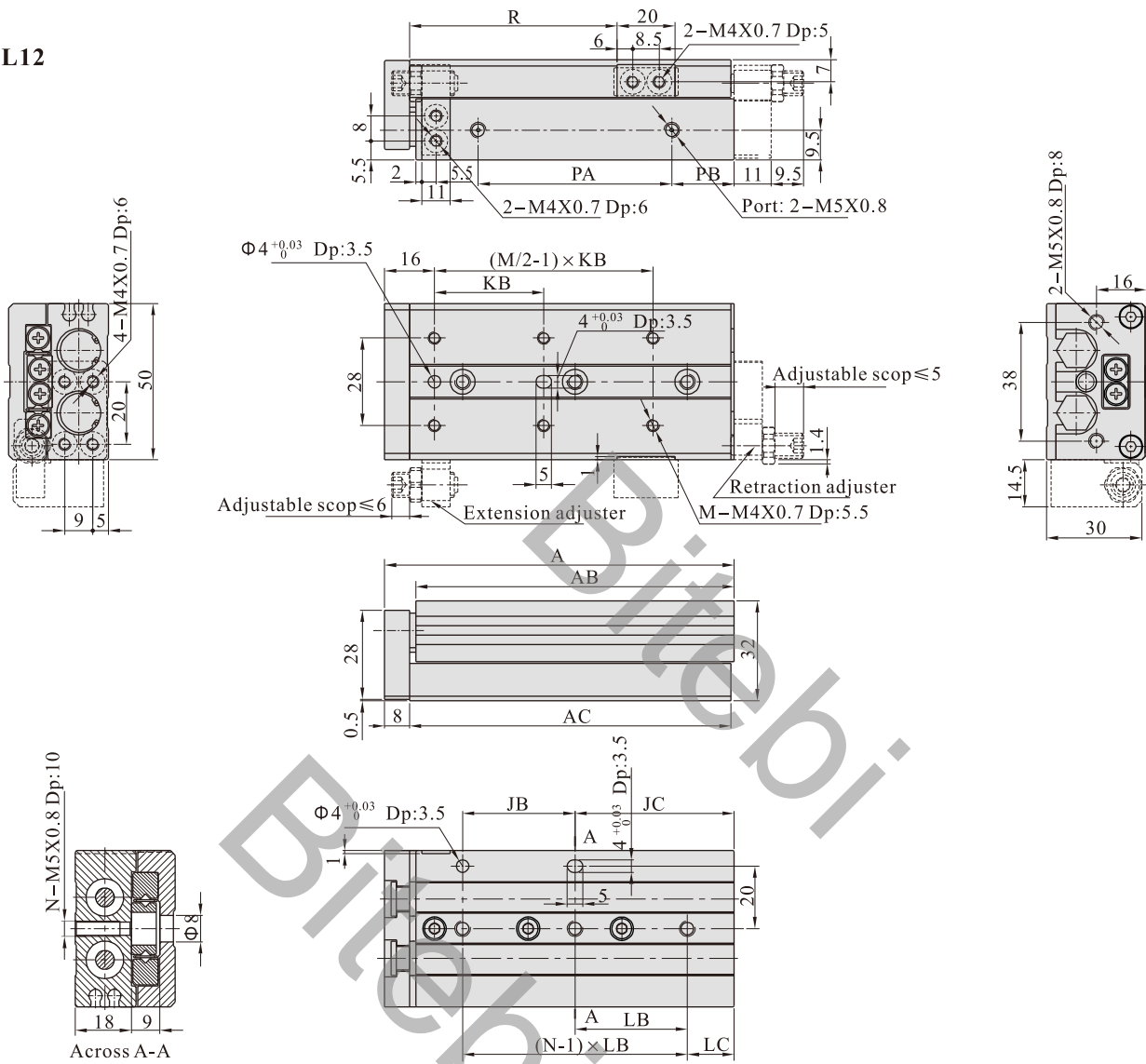

Stroke/Item	A	AB	AC	JB	JC	KB	LB	LC	M	N	PA	PB	R
10	80	70	71	40	15	35	40	15	4	2	39.5	10	25
20	80	70	71	40	15	35	40	15	4	2	39.5	10	35
30	80	70	71	40	15	35	40	15	4	2	39.5	10	45
40	92	82	83	25	42	50	25	17	4	3	51.5	10	55
50	112	102	103	36	51	35	36	15	6	3	61.5	20	65
75	158	148	149	72	61	55	36	25	6	4	87.5	40	90
100	212	202	203	76	111	65	38	35	6	5	131.5	50	115

HLSL12(With shock absorber)

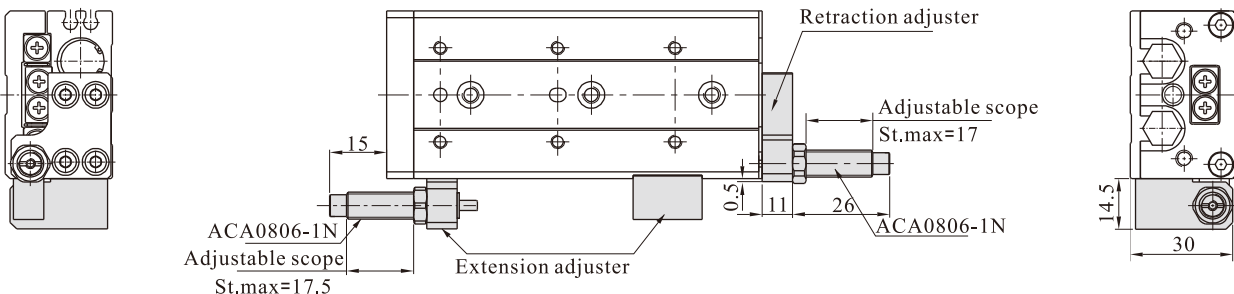

# Slide table cylinder(Cross roller type)

HLS、HLSL Series

HLS16

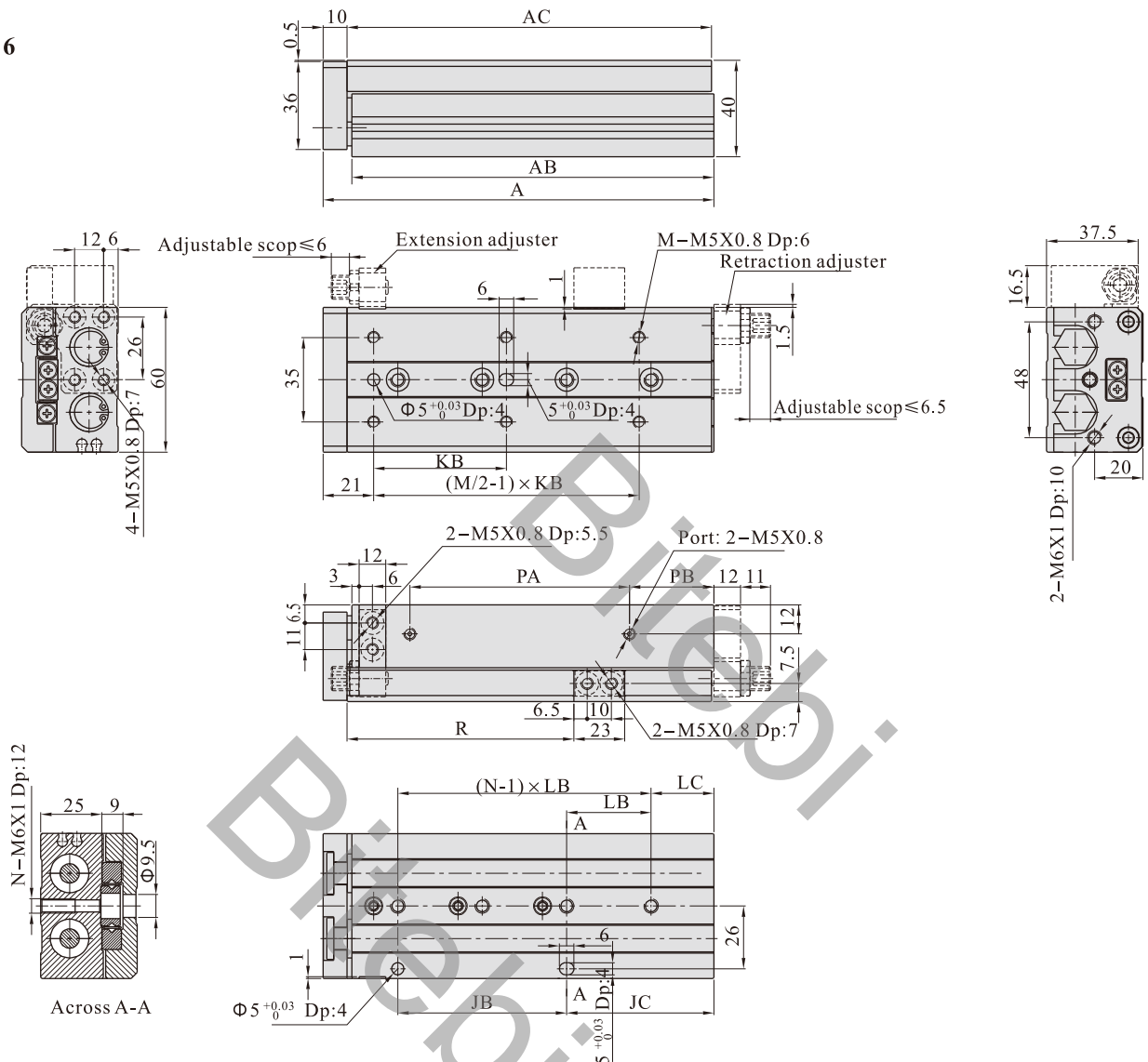

Stroke/Item	A	AB	AC	JB	JC	KB	LB	LC	M	N	PA	PB	R
10	87	75	76	40	16	35	40	16	4	2	42.5	8	28.5
20	87	75	76	40	16	35	40	16	4	2	42.5	8	38.5
30	87	75	76	40	16	35	40	16	4	2	42.5	8	48.5
40	97	85	86	50	16	40	50	16	4	2	52.5	8	58.5
50	112	100	101	30	51	30	30	21	6	3	63.5	12	68.5
75	162	150	151	70	61	55	35	26	6	4	90.5	35	93.5
100	210	198	199	70	109	65	35	39	6	5	118.5	55	118.8
125	260	248	249	70	159	70	35	19	8	7	153.5	70	143.5

## HLS16(With shock absorber)

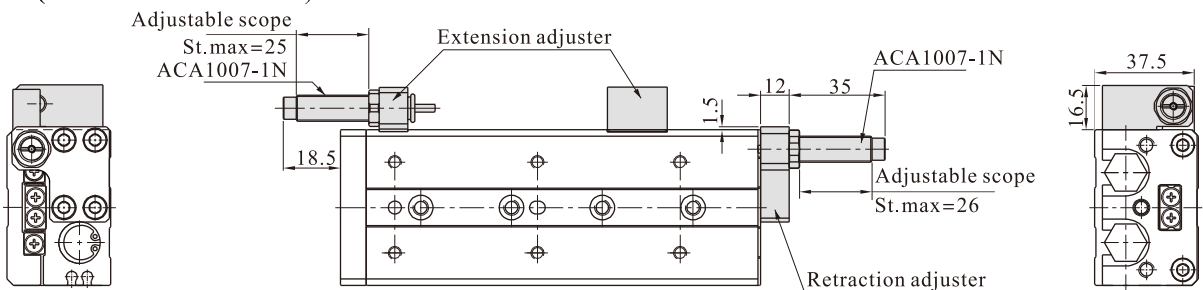

# Slide table cylinder(Cross roller type)

HLS、HLSL Series

HLSL16

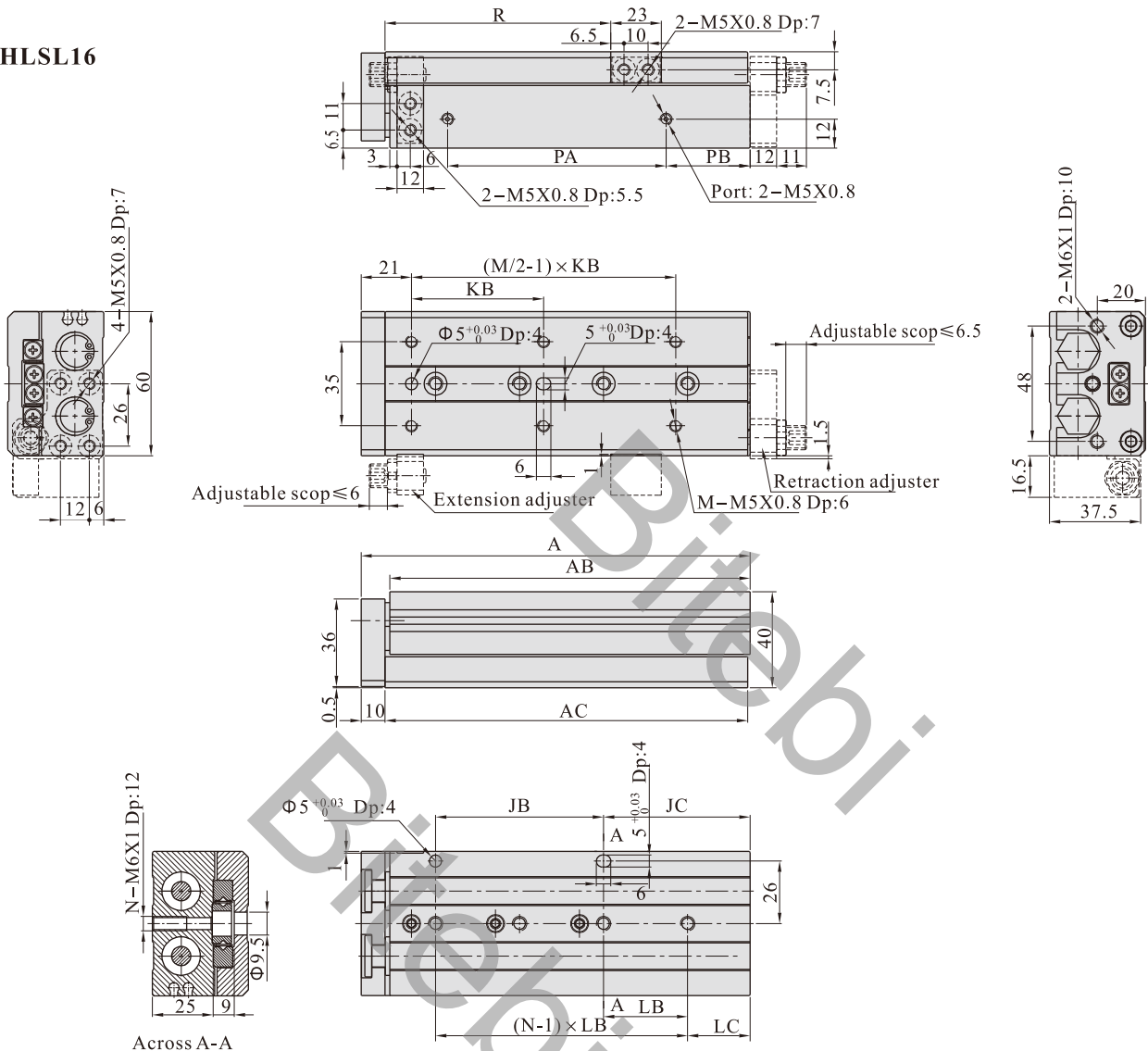

Stroke\Item	A	AB	AC	JB	JC	KB	LB	LC	M	N	PA	PB	R
10	87	75	76	40	16	35	40	16	4	2	42.5	8	28.5
20	87	75	76	40	16	35	40	16	4	2	42.5	8	38.5
30	87	75	76	40	16	35	40	16	4	2	42.5	8	48.5
40	97	85	86	50	16	40	50	16	4	2	52.5	8	58.5
50	112	100	101	30	51	30	30	21	6	3	63.5	12	68.5
75	162	150	151	70	61	55	35	26	6	4	90.5	35	93.5
100	210	198	199	70	109	65	35	39	6	5	118.5	55	118.8
125	260	248	249	70	159	70	35	19	8	7	153.5	70	143.5

HLSL16(With shock absorber)

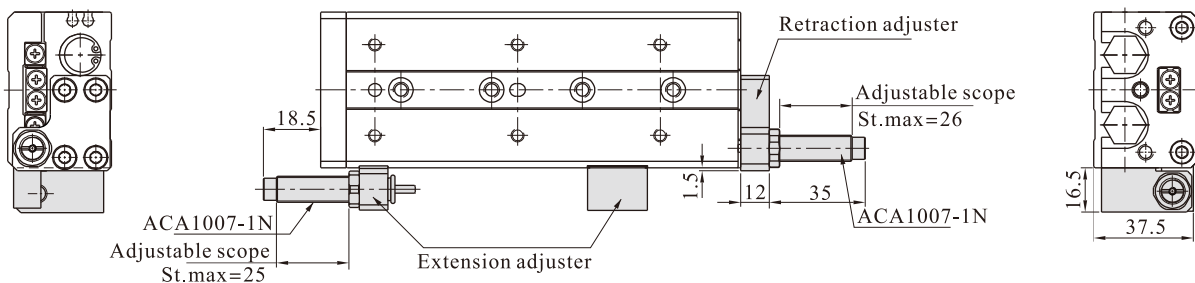

# Slide table cylinder(Cross roller type)

## HLS、HLSL Series

### HLS20

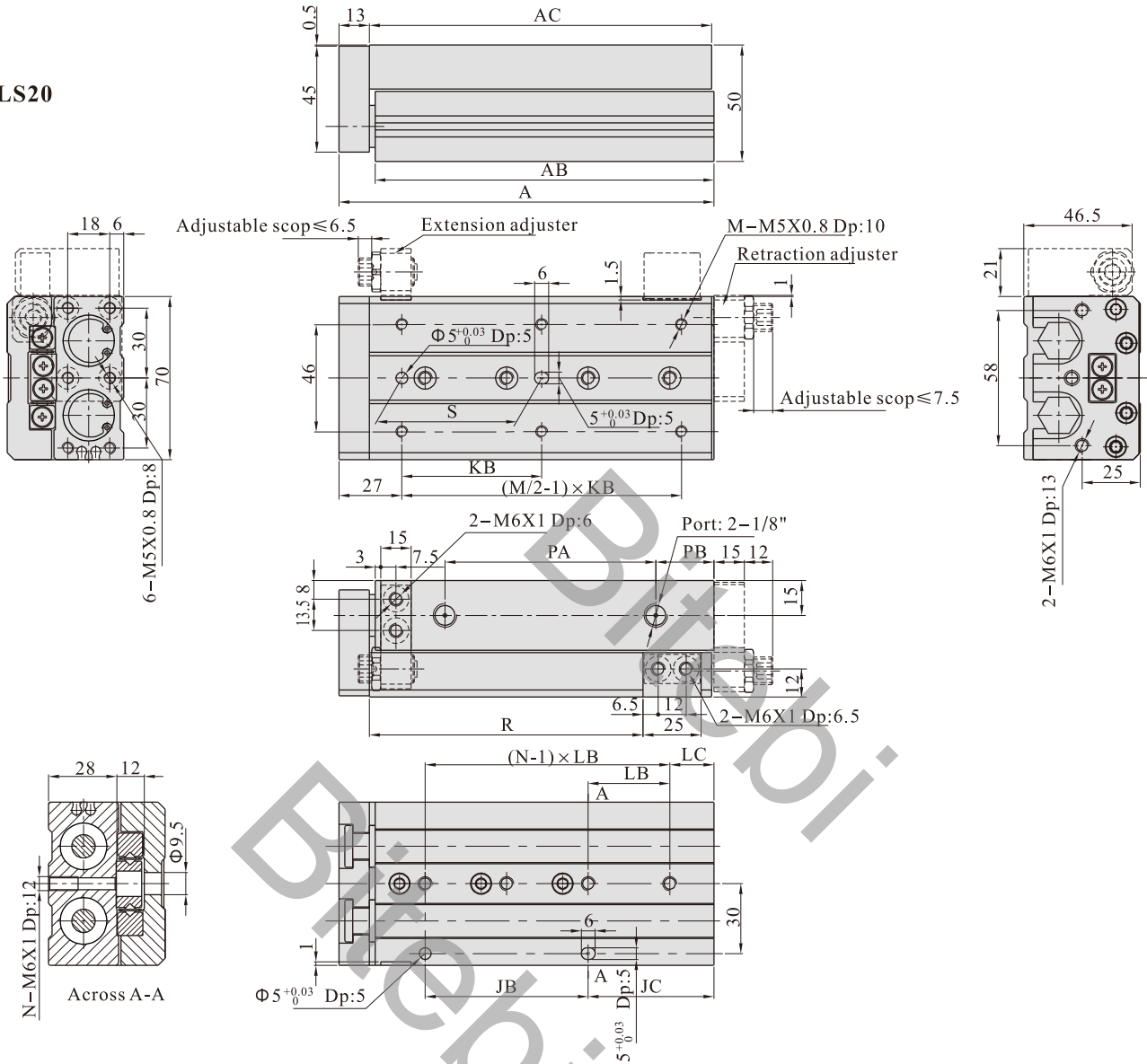

Stroke/Item	A	AB	AC	JB	JC	KB	LB	LC	M	N	S	PA	PB	R
10	97	81.5	83	35	25	50	45	15	4	2	40	43.5	10	32.5
20	97	81.5	83	35	25	50	45	15	4	2	40	43.5	10	42.5
30	97	81.5	83	35	25	50	45	15	4	2	40	43.5	10	52.5
40	107	91.5	93	35	35	60	55	15	4	2	50	53.5	10	62.5
50	122	106.5	108	35	50	35	35	15	6	3	35	68.5	10	72.5
75	161	145.5	147	70	54	60	35	19	6	4	60	107.5	10	97.5
100	214	198.5	200	70	107	70	35	37	6	5	70	115.5	55	122.5
125	268	252.5	254	76	155	70	38	41	8	6	70	154.5	70	147.5
150	320	304.5	306	88	195	80	44	19	8	7	80	186.5	90	172.5

### HLS20(With shock absorber)

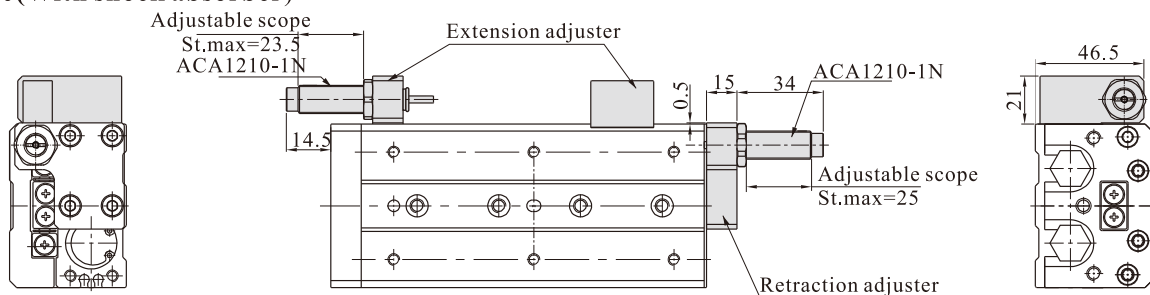



# Slide table cylinder(Cross roller type)

HLS, HLSL Series

HLSL20

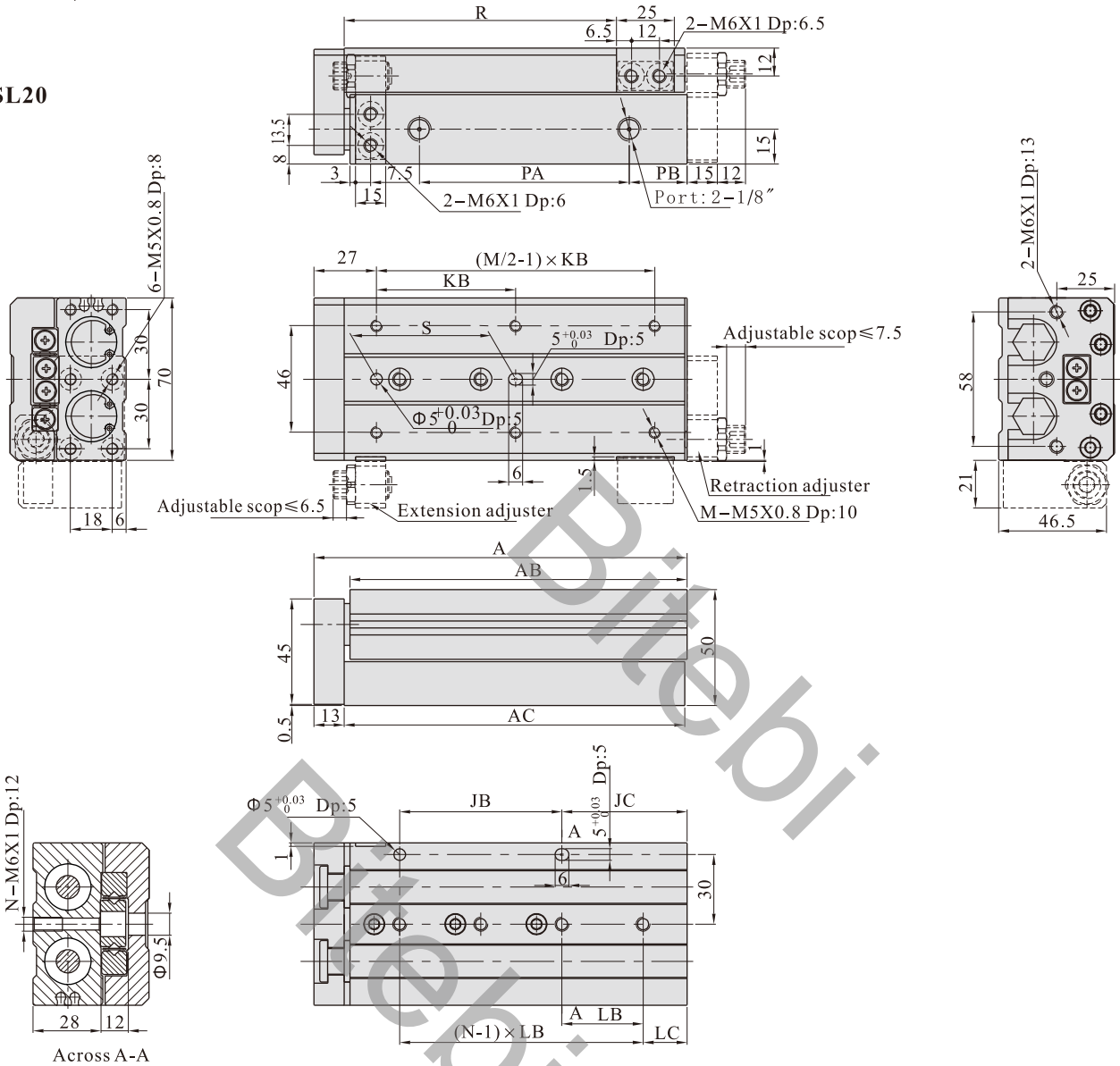

	A	AB	AC	JB	JC	KB	LB	LC	M	N	S	PA	PB	R
10	97	81.5	83	35	25	50	45	15	4	2	40	43.5	10	32.5
20	97	81.5	83	35	25	50	45	15	4	2	40	43.5	10	42.5
30	97	81.5	83	35	25	50	45	15	4	2	40	43.5	10	52.5
40	107	91.5	93	35	35	60	55	15	4	2	50	53.5	10	62.5
50	122	106.5	108	35	50	35	35	15	6	3	35	68.5	10	72.5
75	161	145.5	147	70	54	60	35	19	6	4	60	107.5	10	97.5
100	214	198.5	200	70	107	70	35	37	6	5	70	115.5	55	122.5
125	268	252.5	254	76	155	70	38	41	8	6	70	154.5	70	147.5
150	320	304.5	306	88	195	80	44	19	8	7	80	186.5	90	172.5

HLSL20(With shock absorber)

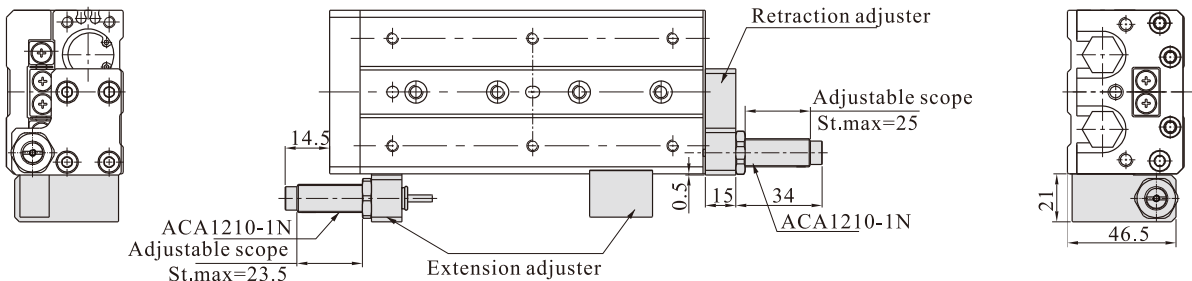



# Slide table cylinder(Cross roller type)

HLS、HLSL Series

## HLSL25

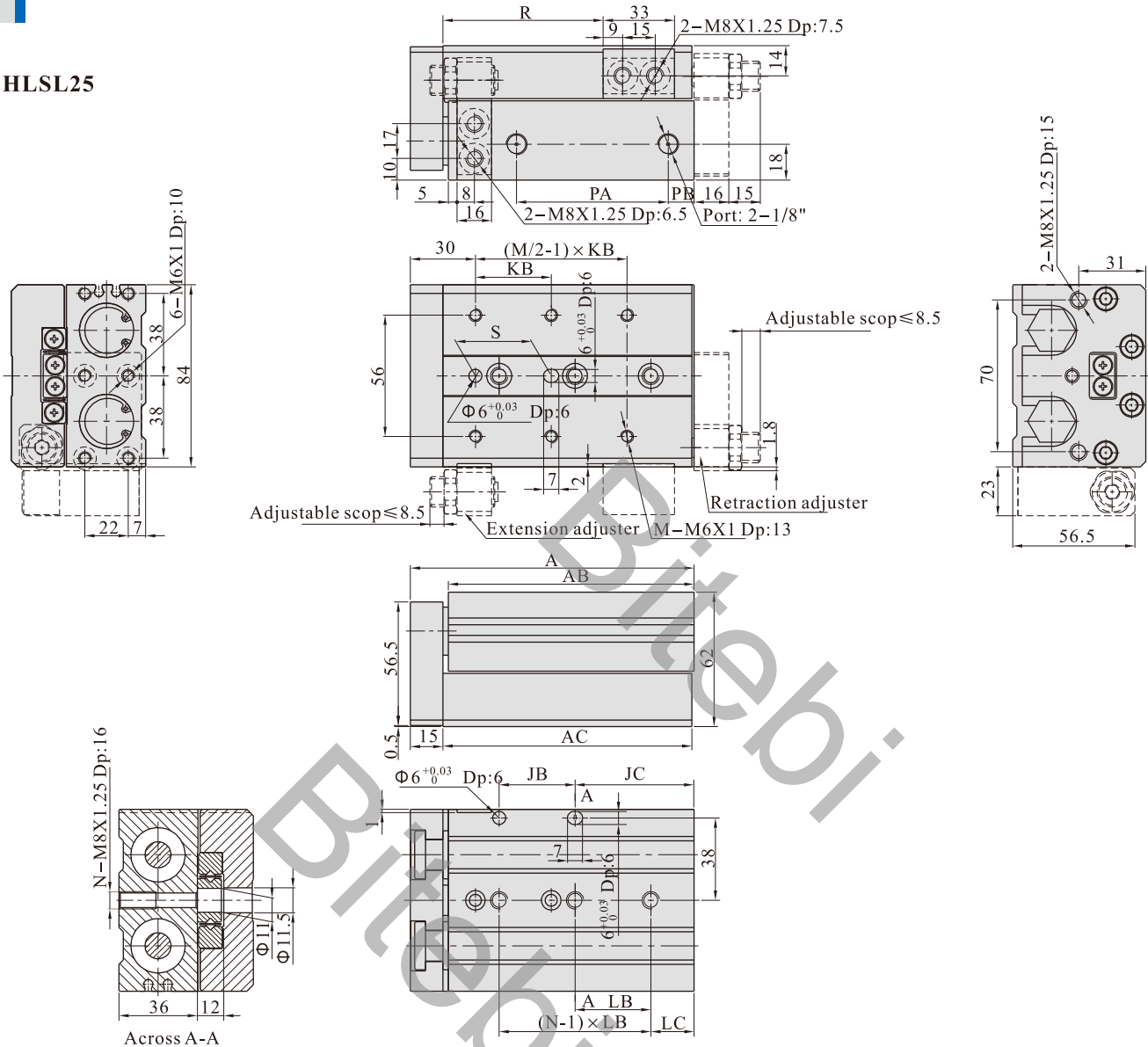

Stroke/Item	A	AB	AC	JB	JC	KB	LB	LC	M	N	S	PA	PB	R
10	108	90.5	92	45	22	50	45	22	4	2	40	47	12	35
20	108	90.5	92	45	22	50	45	22	4	2	40	47	12	45
30	108	90.5	92	45	22	50	45	22	4	2	40	47	12	55
40	118	100.5	102	55	22	60	55	22	4	2	50	57	12	65
50	131	113.5	115	35	55	35	35	20	6	3	35	70	12	75
75	172	154.5	156	70	61	60	35	26	6	4	60	90	33	100
100	213	195.5	197	70	102	70	35	32	6	5	70	119	45	125
125	271	253.5	255	76	154	75	38	40	8	6	75	155	67	150
150	311	293.5	295	80	190	80	40	30	8	7	80	180	82	175

## HLSL25(With shock absorber)

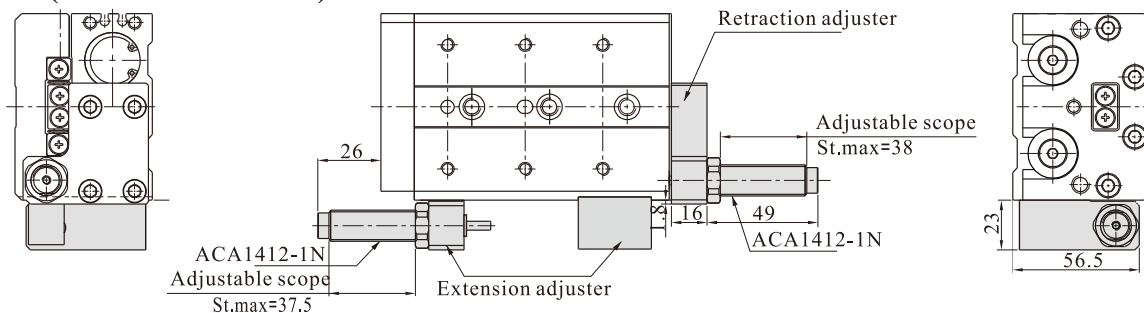

### Accessory selection

	Accessories\Bore size		6	8	12
	Standard (HLS)	Both ends	A(Adjustable rubber stopper)	F-HLQ6A	F-HLS8A
B(Shock absorber)			×	F-HLS8B	F-HLS12B
Extention		AS(Adjustable rubber stopper)	F-HLQ6AS	F-HLQ8AS	F-HLQ12AS
		BS(Shock absorber)	×	F-HLQ8BS	F-HLQ12BS
Retraction		AF(Adjustable rubber stopper)	F-HLQ6AF	F-HLS8AF	F-HLS12AF
		BF(Shock absorber)	×	F-HLS8BF	F-HLS12BF
	Accessories\Bore size		16	20	25
	Standard (HLS)	Both ends	A(Adjustable rubber stopper)	F-HLS16A	F-HLS20A
B(Shock absorber)			F-HLS16B	F-HLS20B	F-HLS25B
Extention		AS(Adjustable rubber stopper)	F-HLQ16AS	F-HLQ20AS	F-HLQ25AS
		BS(Shock absorber)	F-HLQ16BS	F-HLQ20BS	F-HLQ25BS
Retraction		AF(Adjustable rubber stopper)	F-HLS16AF	F-HLS20AF	F-HLS25AF
		BF(Shock absorber)	F-HLS16BF	F-HLS20BF	F-HLS25BF
	Accessories\Bore size		6	8	12
	Symmetrical (HLSL)	Both ends	A(Adjustable rubber stopper)	F-HLQL6A	F-HLSL8A
B(Shock absorber)			×	F-HLSL8B	F-HLSL12B
Extention		AS(Adjustable rubber stopper)	F-HLQ6AS	F-HLQ8AS	F-HLQ12AS
		BS(Shock absorber)	×	F-HLQ8BS	F-HLQ12BS
Retraction		AF(Adjustable rubber stopper)	F-HLQL6AF	F-HLSL8AF	F-HLSL12AF
		BF(Shock absorber)	×	F-HLSL8BF	F-HLSL12BF
	Accessories\Bore size		16	20	25
	Symmetrical (HLSL)	Both ends	A(Adjustable rubber stopper)	F-HLSL16A	F-HLSL20A
B(Shock absorber)			F-HLSL16B	F-HLSL20B	F-HLSL25B
Extention		AS(Adjustable rubber stopper)	F-HLQ16AS	F-HLQ20AS	F-HLQ25AS
		BS(Shock absorber)	F-HLQ16BS	F-HLQ20BS	F-HLQ25BS
Retraction		AF(Adjustable rubber stopper)	F-HLSL16AF	F-HLSL20AF	F-HLSL25AF
		BF(Shock absorber)	F-HLSL16BF	F-HLSL20BF	F-HLSL25BF

Note): A=AS+AF; B=BS+BF.

### F - HLS 20 AF



#### ① Accessory

#### ② Cylinder model

#### ③ Bore size

HLS: Standard	6 8 12
HLSL: Symmetrical	16 20 25

#### ④ Accessory type[Note]

- A: Adjustable rubber stopper(Both ends)
- AF: Adjustable rubber stopper(Retraction)
- B: Shock absorber(Both ends)
- BF: Shock absorber(Retraction)

[Note]The list accessories are for HLS cylinder.

Accessories that are adaptable to other cylinder are not shown. Please refer to accessorylist for selection and ordering information.

### Dimensions

AS: Adjustable rubber stopper(Extention)

Body Mounting

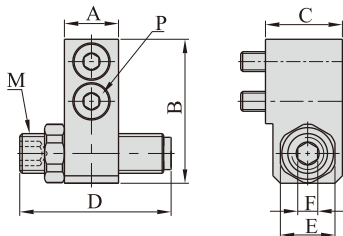
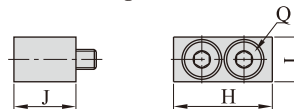

Table Mounting



Bore size/Item	Adjusting stroke range	A	B	C	D	E	F	M	P	H	I	J	Q
6	5	7	19	10.5	16.5	8	3	M6×1.0	M2.5 Length:10	12.5	6.5	10.5	M2.5 Length:10
8	5	8.5	21.5	14	21.5	11	4	M8×1.0	M3 Length:14	14.5	8	12	M3 Length:14
12	5	11	29	15.5	31.5	11	4	M8×1.0	M4 Length:16	20	9	13.5	M4 Length:12
16	5	12	36	17.5	24	14	5	M10×1.0	M5 Length:16	23	10.5	17	M5 Length:16
20	5	15	44.5	22	28	17	6	M12×1.0	M6 Length:20	25	12.5	21	M6 Length:20
25	5	16	53.5	24	32	19	6	M14×1.5	M8 Length:20	33	16.5	23	M8 Length:20

# Slide table cylinder(Cross roller type)

HLS、HLSL Series—Accessories

## BS: Shock absorber(Extension)

### Body Mounting

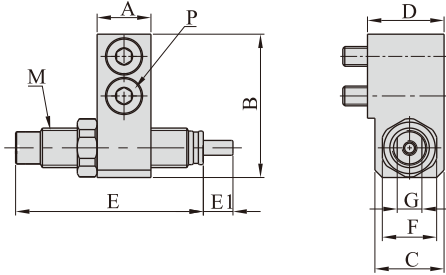

### Table Mounting

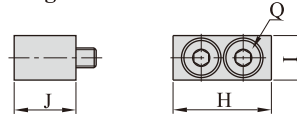

Bore size\Item	A	B	C	D	E	E1	F	G	M	P	H	I	J	Q
8	8.5	21.5	12.5	14	40	6	11	7	M8×1.0	M3 Length:14	14.5	8	12	M3 Length:14
12	11	29	14	15.5	40	6	11	7	M8×1.0	M4 Length:16	20	9	13.5	M4 Length:12
16	12	36	16	17.5	49	7	14	9	M10×1.0	M5 Length:16	23	10.5	17	M5 Length:16
20	15	44.5	20	22	53.5	10	17	11	M12×1.0	M6 Length:20	25	12.5	21	M6 Length:20
25	16	53.5	22	24	68.5	12	19	12	M14×1.5	M8 Length:20	33	16.5	23	M8 Length:20

## AF: Adjustable rubber stopper(Retraction)

### For standard type

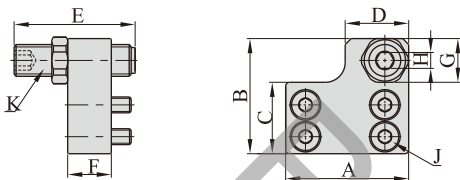

### For symmetrical type

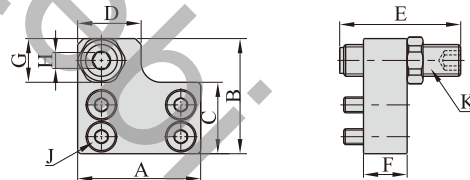

Bore size\Item	Adjusting stroke range	A	B	C	D	E	F	G	H	J	K
6	5	18	19	11	8	21.5	7	8	3	M2.5 Length:6	M6×1.0
8	5	24	22.5	13	14	21.5	8.5	11	4	M3 Length:8	M8×1.0
12	5	31	29	18	16	21.5	11	11	4	M4 Length:12	M8×1.0
16	5	37	37.5	23	18	24	12	14	5	M5 Length:12	M10×1.0
20	5	45.5	47	28.5	23	28	15	17	6	M5 Length:16	M12×1.0
25	5	54	56	34	28	32	16	19	6	M6 Length:18	M14×1.5

## BF: Shock absorber(Retraction)

### For standard type

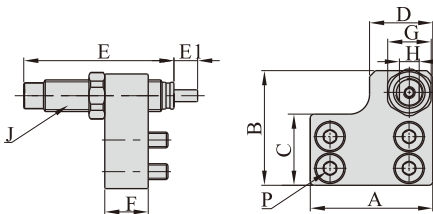

### For symmetrical type

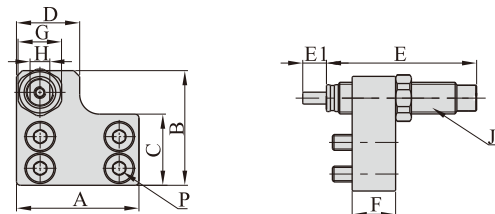

Bore size\Item	A	B	C	D	E	E1	F	G	H	J	P
8	24	22.5	13	14	40	6	8.5	11	7	M8×1.0	M3 Length:8
12	31	29	18	16	40	6	11	11	7	M8×1.0	M4 Length:12
16	37	37.5	23	18	49	7	12	14	9	M10×1.0	M5 Length:12
20	45.5	47	28.5	23	53.5	10	15	17	11	M12×1.0	M5 Length:16
25	54	56	34	28	68.5	12	16	19	12	M14×1.5	M6 Length:18